

ROBINSON ENGINEERING COMPANY

Operation & Maintenance Manual

C r a n e B o s s®

Digital Radio Remote Control

**Model 300
Series K**

September, 1999

TABLE OF CONTENTS

		PAGE
SECTION 1	GENERAL INFORMATION	
1.1	SCOPE	1-1
1.2	SYSTEM DESCRIPTION	1-1
1.3	WARRANTY	1-4
SECTION 2	OPERATION	
2.1	RECEIVING EQUIPMENT	2-1
2.2	TRANSMITTER	2-1
2.3	OPERATING PROCEDURE	2-1
2.4	MISCELLANEOUS OPERATING INFORMATION	2-2
SECTION 3	PRINCIPLE OF OPERATION	
3.1	RADIO CONTROL SYSTEM	3-1
3.2	TRANSMITTER	3-2
3.3	RECEIVING EQUIPMENT	3-5
SECTION 4	INSTALLATION INFORMATION	
4.1	SCOPE	4-1
4.2	MOUNTING	4-1
4.3	TRANSFER SWITCH	4-2
4.4	OUTPUT CIRCUITRY	4-5
4.5	INTERFACE LOGIC PANELS	4-6
4.6	START-UP PROCEDURE	4-7
SECTION 5	MAINTENANCE	
5.1	PREVENTIVE MAINTENANCE	5-1
5.2	CORRECTIVE MAINTENANCE	5-1
5.3	REPLACEABLE PARTS	5-12
	APPENDICES	
I	INDEX	I-1
II	OPTIONS	II-1

TABLE OF FIGURES

FIGURE	TITLE	PAGE
3-1	BLOCK DIAGRAM, TRANSMITTER	3-3
3-2	BLOCK DIAGRAM, RECEIVING EQUIPMENT	3-4
4-1	TYPICAL TRANSFER SWITCH & MAIN LINE CONTACTOR CIRCUIT	4-3
4-2(K)	OUTPUT CIRCUIT FUNCTIONAL DIAGRAMS	4-4
5-1	TRANSMITTER COMPONENTS	5-3
5-2(K)	CONTROLLER	5-7 & 5-8

DRAWING LIST

NUMBER	TITLE
15-1763	OUTPUT CIRCUITS
12-1738	SCHEMATIC, CONTROLLER
12-1608	OUTLINE, CRANE RADIO CONTROL

SECTION 1

GENERAL INFORMATION

1.1 SCOPE

This manual contains information necessary to install, operate and maintain Crane Boss 300 Radio Remote Control Systems. The information is generally applicable to all Crane Boss 300 systems manufactured by Robinson Engineering Company.

1.2 SYSTEM DESCRIPTION

1.2.1 General – The “300” system is equipped with controls and accessories required for reliable electrical operation of a crane or other machinery from a portable wireless control transmitter.

1.2.2 Control functions provided:

On/Off/Emergency Stop/Indicating Light

‘B’	-	5-step reversing
‘T(1)’	-	5-step reversing
‘H(1)’	-	5-step reversing
‘Aux 1’	/	‘Aux 2’*

* See “Options” Appendix

1.2.3 Characteristic features are:

1. Each system consists of a portable control transmitter which operates in conjunction with receiving equipment installed on the machinery structure and electrically connected to the magnetic controllers.
2. "Fail-safe" circuits are used throughout the system.
3. The command link is capable of handling all motions simultaneously.
4. The system uses digital pulse code frequency modulation. It was developed specifically for industrial control.
5. The system utilizes fully solid state electronic circuits, with heavy duty relay contact output circuits.
6. Maintenance requirements are greatly reduced by modular design and use of digital switching circuits. No special test equipment is required.
7. Radio control of several units in the same plant without interference is entirely practical. Each transmitter transmits a unique address code, which prevents response by other than the intended unit. In addition, the operating frequencies of different units are staggered within the frequency band to prevent interference. Proper selection of address codes and operating frequencies with respect to physical separation provides control of multiple installations with no practical limitation on the number at one location.

- 1.2.4 Transmitter – The transmitter is a portable unit that is carried by the operator. A shoulder harness and belt clips are provided to enable the operator to conveniently carry the unit, while leaving hands free to operate controls. Switches on the transmitter control all functions as labeled.

The portable transmitter weight is approximately 4 pounds. The transmitter includes an internal antenna and has a battery assembly attached*. The battery assembly uses 4 “AA” cells that may be disposable (alkaline, carbon zinc, etc.) The alkaline cells supplied with the transmitter will provide approximately 100 to 150 hours of continuous transmitter operation. (This will provide one to three months or more of moderate crane service).

Rechargeable (NiCd), that may be recharged on commonly available chargers (not furnished by Robinson Engineering Company), are also usable*.

- 1.2.5 Receiving Equipment – The receiving equipment cabinet is mounted on the machinery and contains the radio receiving unit, decoding equipment and relays to convert the radio signal from the transmitter to signals suitable for operation of (magnetic) controls’ contactors.

* See “Options” Appendix.

1.3 GUARANTEE

Manufacturer warrants the delivered remote control system to be free of defective material and workmanship and agrees to remedy any such defect within two years of first party purchase at no charge to the purchaser upon return of defective parts to factory. Defects caused by improper installation, maintenance, misuse, tampering, neglect, accident, or use in violation of manufacturer's written instructions, shall not be covered by this warranty. Manufacturer guarantees that remote control system will perform as outlined in this manual.

Transferring of this warranty is acceptable and recommended. Please notify this factory of any and all transfers.

SECTION 2

OPERATION

2.1 RECEIVING EQUIPMENT

Normal operating procedures is to leave receiving equipment energized at all times. (Power switch “On”, neon indicator lighted). The unit can then be readily placed in operation by means of the portable control transmitter.

2.2 TRANSMITTER

The transmitter should be stored in a secure location when not being used, with “Power” key removed.*

2.3 OPERATING PROCEDURE

To place the unit in operation, proceed as follows:

1. Suspend transmitter on the operator by means of shoulder harness or belt clips, or on its mounting bracket. Make sure all attachments are secure to prevent accidental dropping of the unit.
2. Operator should position himself so as to have a clear view of the motions and actions.
3. If multi-crane unit is being used, make certain proper selection is made.
4. Insert “power” key and turn on (clockwise).
5. With all operating controls in neutral position, push “Start/Reset, On, Off” Toggle to “Reset” position, and let it (spring) return to “On”. Master indicating light will flash.
6. Wait at least three seconds, and then depress either “Enable/Sig” Pushbutton. Master Relay and Mainline Contactor on Crane are energized.

* See “Options” Appendix.

7. Operating desired control operators can now move machinery. All motion controls are spring loaded to neutral.
8. In the event of an emergency situation, move “Start/Rreset, On, Off” Toggle to “Off” position and turn off “Power” key.
9. Upon completion of use, replace transmitter in designated storage location with “Power” key removed.*

2.4 MISCELLANEOUS OPERATING INFORMATION

Abnormal electrical conditions during operation will de-energize control circuits, stopping motion. This can be caused by any one of a number of abnormal conditions. Among these are:

1. Weak or improper radio signal.
2. Interruption of power to receiving equipment.
3. Radio interference.
4. Malfunction of radio equipment.
5. Malfunction of machine electrical equipment.

If the abnormal condition is temporary, control can be resumed by repeating steps 4. through 8. of paragraph 2.3. The exact sequence of operation must be followed to accomplish operation of safety circuits in the receiving equipment.

* See “Options” Appendix

SECTION 3

PRINCIPLE OF OPERATION

3.1 RADIO CONTROL SYSTEM

The Crane Boss system is simple to operate. The transmitter unit incorporates an easily operated control lever for each crane motion. Moving the lever in either direction from the neutral position moves the crane in that direction. A “Start/Reset, On, Off” Toggle energizes the Address Relay, followed by the Master Circuit after depressing an Enable/Sig pushbutton, and hence the Main Line Contactor. All function control levers return to neutral (dead-man action) when released, and motion stops. Fail-safe features are used throughout the circuitry. All crane motion stops in case of malfunction.

The transmitter(s) in your Crane Boss system transmit unique digital crane address codes to each crane. This prevents any mix-up in crane response. Only one crane responds to one special code when transmitted. Hundreds of these address codes are available. For added protection, operating frequencies of each transmitter in the same area can be staggered within the frequency band to prevent interference. The proper selection of digital address codes and operating frequencies relative to physical separation permits control of an unlimited number of cranes in the same plant, area or city.

3.2 TRANSMITTER

The Transmitter is a battery operated frequency modulation radio transmitter. Incorporated with the transmitter is an antenna and disposable batteries.* Transmitter carrier frequency is crystal controlled. When the various switches are actuated, coded control signals are sent to the receiving equipment via the antenna. A block diagram of the transmitter is shown by Fig. 3-1.

The RF Assembly generates the radio frequency signal radiated by the antenna, and is frequency modulated by a pulse code modulation signal. This modulation signal is generated by the Coder Assembly and consists of a series of synchronizing pulses determined by the position of the various function controls, which are actuated by the operator.

Coder Assembly used in all transmitters is identical in function and is interchangeable. Variation in code format between systems is accomplished by means of factory connections on the Junction Board, by the Address Plug, and by wiring to the various control devices. All RF Boards for the same frequency band are identical and interchangeable except for the frequency.

In multiple system installations a given transmitter may be converted from control of one crane to another by changing the Address Plug installed in the transmitter**. This same effect is used by the Multi-crane (Universal) selector switch*. The Scanning Receivers used in multiple systems installations are normally supplied with capability of receiving all transmitting frequencies used at that installation.

** See 5.2.2.3

* See "Options" Appendix

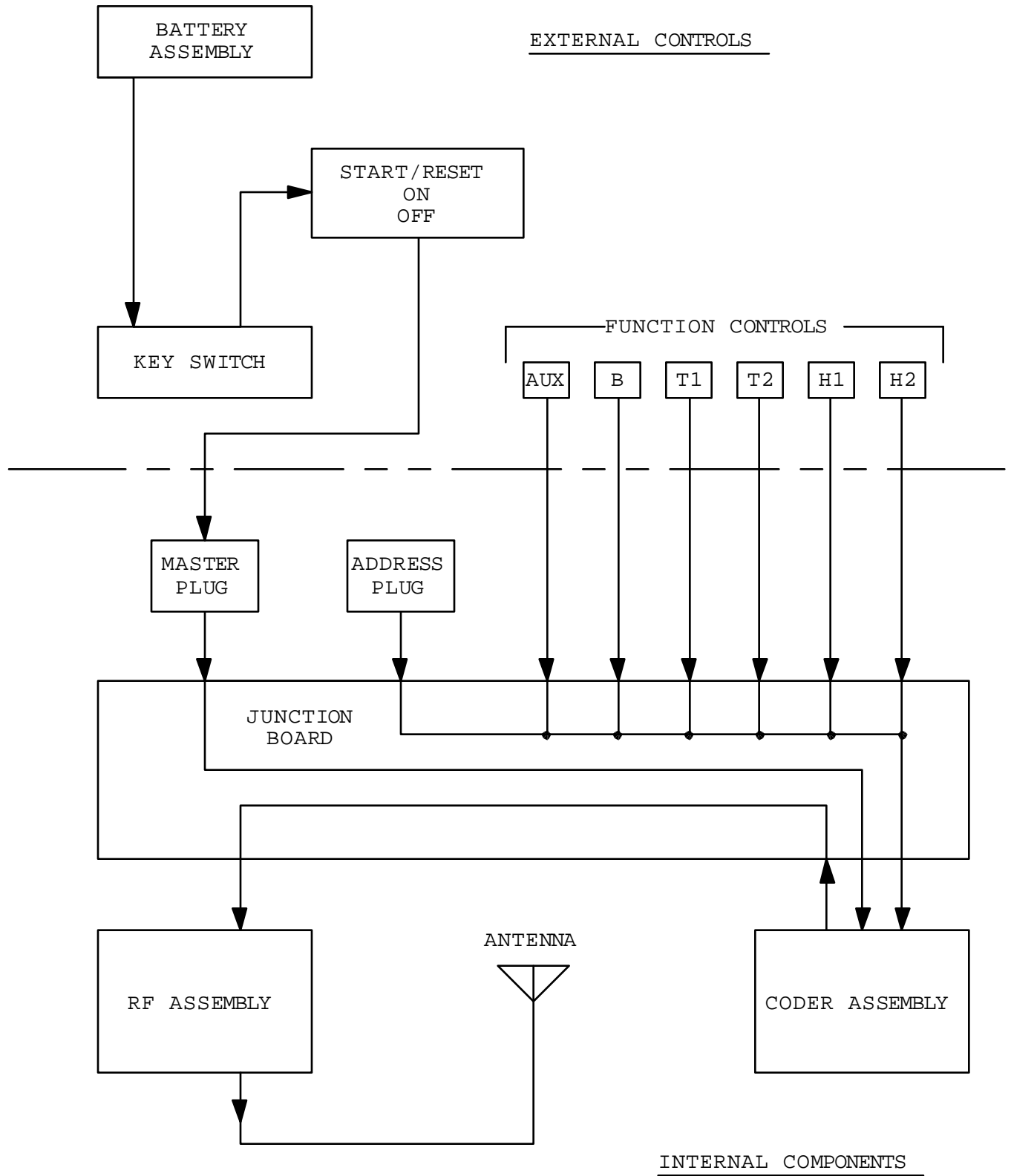

FIG. 3-1: BLOCK DIAGRAM, TRANSMITTER

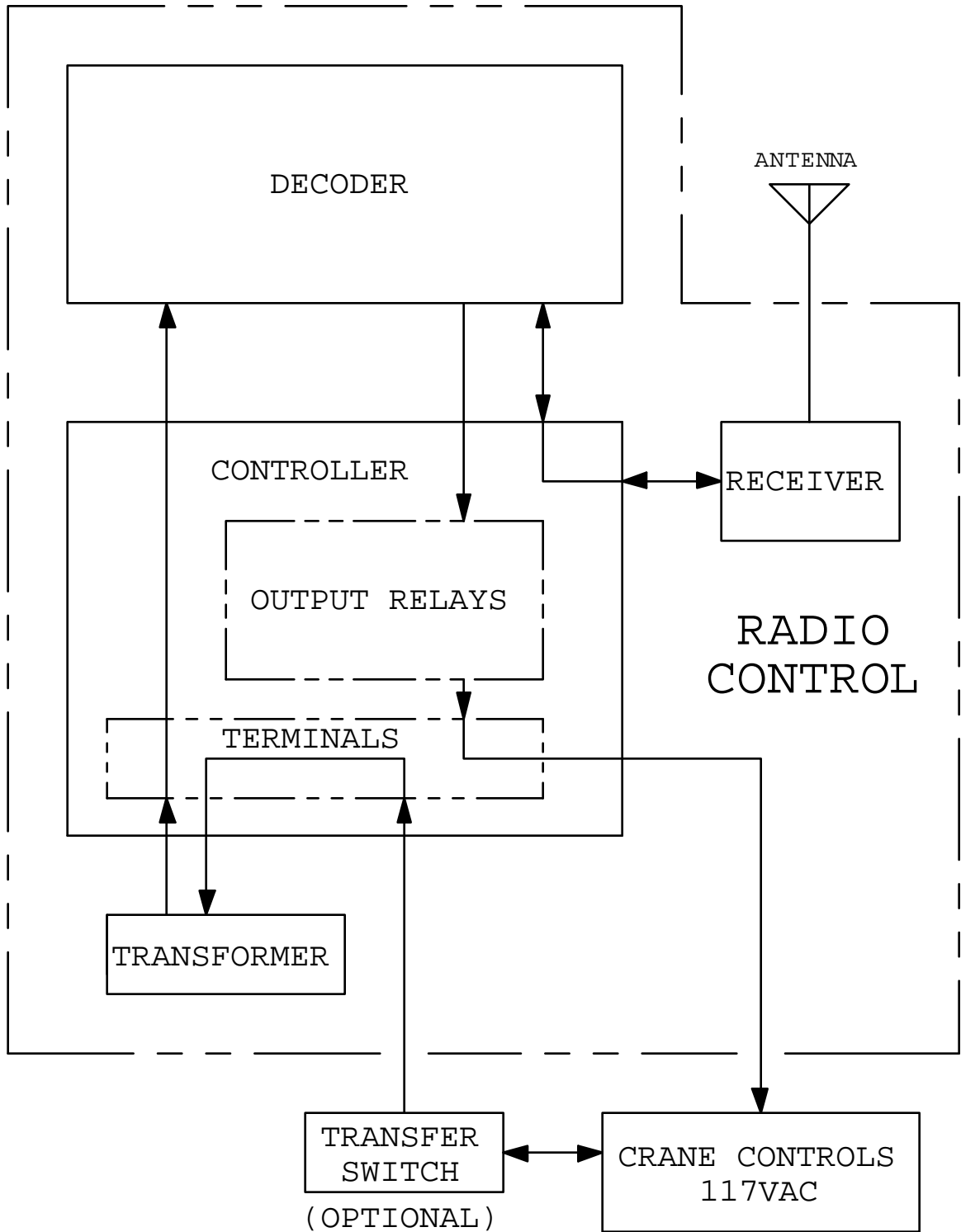

FIG. 3-2: BLOCK DIAGRAM, RECEIVING EQUIPMENT

3.3 RECEIVING EQUIPMENT

Figure 3-2 shows a block diagram. The radio signal from the transmitter is received by the antenna, which is connected to the Receiver by coaxial cable. Receiver data output is fed to the Decoder, where it is decoded and signals suitable for operation of the output relays are generated. The output relays provide heavy-duty control circuits to the basic machine electrical controllers.

3.3.1 Antenna - The Antenna is pre-tuned for the frequency band used.

3.3.2 Receiver - The Receiver amplifies and detects the frequency modulated pulse code signal and includes filtering and shaping circuits to process the signal. Data output consists of rectangular pulses of 12 volts amplitude which are a replica of the transmitter coder output.

The Receiver is a synthesized frequency controlled scanning type receiver, which continuously scans all selected channels until a signal is received which contains the proper address code. When proper address code is received, scanning stops and, the receiver remains “locked-on” that channel for as long as the code remains.

Channels can be turned “Off” or “locked-out” when unused or turned “On” when other equipment is added.

A “VOLUME” control is provided to permit audio monitoring, via internal loudspeaker, of the received signal for test and maintenance purposes. This control has no effect on the control function of the system and should be left in the full (CCW) off position during normal operation.

3.3.3 Decoder - The receiver data output is connected to the Decoder through the Controller, where it is processed into form suitable for operation of the Relays. The Decoder also performs certain synchronization, safety interlock, and digital filtering and noise rejection functions. All DC voltages originate in the Decoder.

3.3.4 Address Code - The address is a two digit hexadecimal number that is set at the factory. The number for each system is shown in the “Code” number block in the lower right corner of the Controller.

3.3.5 Output Relays - Relay contact logic circuits provide additional safety sequencing and interlocking functions. Output circuits are connected to terminal blocks for connection to magnetic controllers. Output relay circuits are rated for operation of up to NEMA size 4 contactors at a maximum coil voltage of 125 volts A.C.

SECTION 4

INSTALLATION INFORMATION

4.1 SCOPE

This section is intended as aid to preparing for mounting and interconnection of Crane Boss to machinery, crane or monorail. The examples and suggestions made as to mounting and interconnection are based upon typical uses and past experience; depending upon application, these may or may not be applicable or appropriate.

The installer is cautioned to assure that requirements of applicable Codes and Ordinances are complied with.

4.2 MOUNTING – RECEIVING EQUIPMENT

- 4.2.1 Refer to Outline Drawing for mounting dimensions and clearances required.
- 4.2.2 Rigidly mount, as for any control panel, the Receiving Cabinet to the structure of the equipment to be remotely controlled. Allow access for conduit entry as noted on the Outline Drawing.
- 4.2.3 Mounting of the Indicating Light (if used) is accomplished by normal electrical wiring procedures. Be sure of visibility from operating area. Also, that it be conveniently accessible for service (changing bulb, etc.). Terminals IL and X2 are used for the Indicating Light.

- 4.2.4 The antenna is installed by plugging into the jack on the bottom of the Radio Crane Control cabinet.
- 4.2.4.1 If an antenna location other than the bottom of the cabinet is required, an optional kit for remote installation is available.*
- 4.2.4.2 Proper mounting and location of antenna is imperative for signal to reach decoding and output circuits. (See Notes on Outline Drawing)).
- 4.2.5 Wherever the “other” means of control (console, pendant, etc.) is located (trolley, bridge) is probably the simplest wiring location for the radio control cabinet. The only distinct difference between pushbutton and radio control is that 117 VAC must be available for radio power supply. Pushbuttons will have as a common the “hot” lead. The other leg of the transformer (X2) must often be added by conductor bar, festooning, or by other means.

4.3 TRANSFER SWITCH

- 4.3.1 Mutually exclusive transferring of control modes is often used: “Pushbutton-Radio”, “Cab-Radio”, “Pendant-Radio”, “Console-Radio”, etc. The mutual exclusivity is most simply obtained by appropriately defeating the other mode’s power feed, as well as, opening any normally closed circuits. See Fig. 4-1.

* See “Options” Appendix.

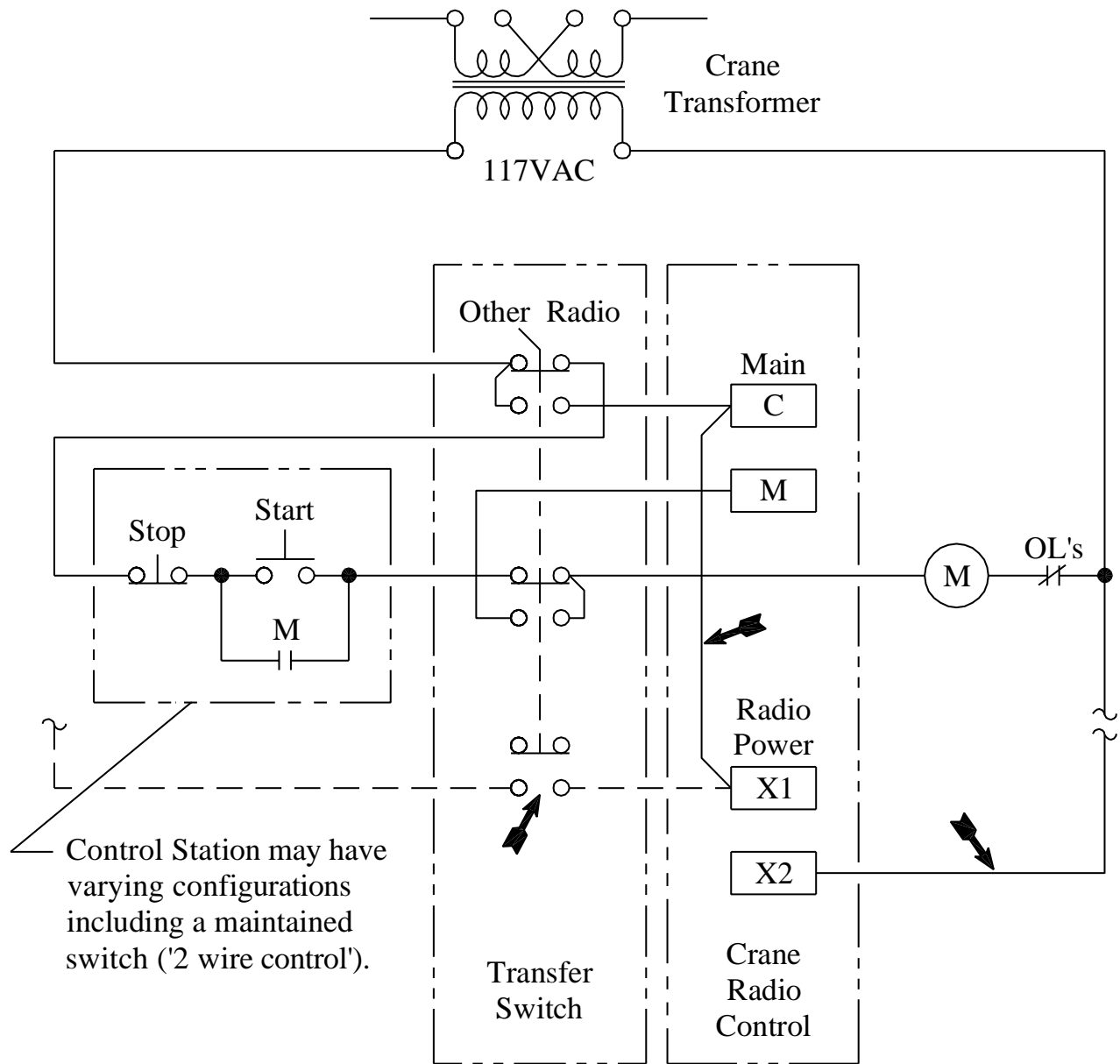

➡ If Radio Power is to be separate from Main Power, omit jumper from C (Main) to X1 and add Transfer Switch contact with dashed line connection as shown. X2 must be connected to the same power source as X1.

NOTE: This diagram is an example only. Equipment control circuits may vary greatly. Control connections should be carefully considered to provide proper operation and avoid feedback circuits.

FIG. 4-1:
TYPICAL TRANSFER SWITCH & MAIN LINE CONTACTOR CIRCUIT

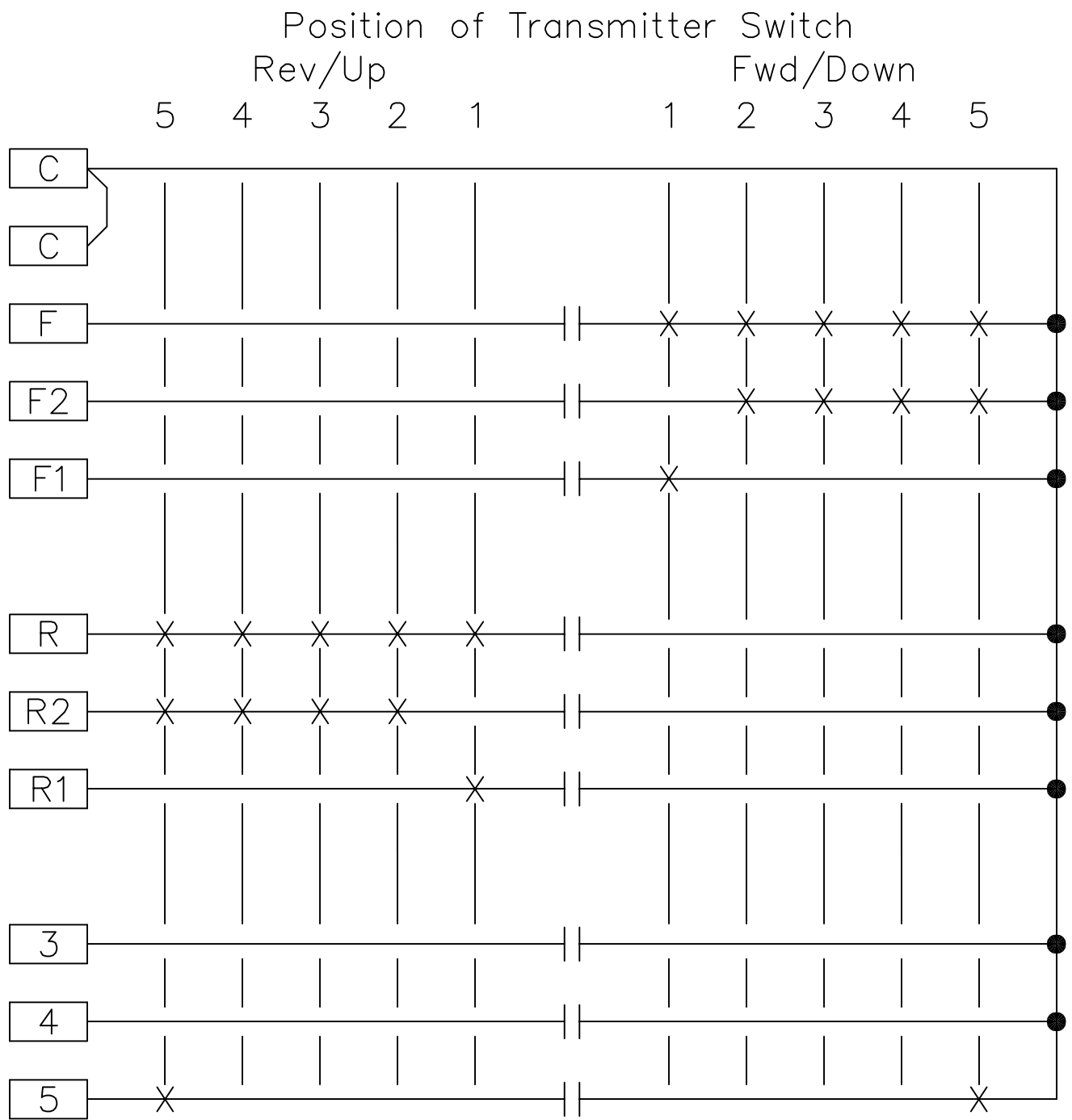

X: Indicates Closed Circuit

Fig 4-2(K): Output Circuit Functional Diagram, 'K' Series
(Relay Contacts Simplified)

4.4 OUTPUT CIRCUITRY

- 4.4.1 Main circuit - connect Main Contactor (M) in a manner similar to Fig. 4-1. The circuit should provide for the Main Contactor to be energized when the circuit from “C” (Main) to “M” terminals is closed. Be certain to use a Transfer Switch if any “other” control exists.

A “Stop” circuit (momentary), from “C” (Main) to “Stop” terminals, is available to unlatch a latching main contactor or similar applications.

Safeties, such as N.C. master switch contacts in series between “M” terminal and Main Contactor coil should be employed whenever practical.

- 4.4.2 The output of the Crane Boss 300 digital radio remote control is by heavy-duty relay contacts. One normally open circuit is available for each function direction and each speed output. See Fig. 4-2L and Output Circuits Drawing for logic of internally, pre-wired circuits.

- 4.4.3 Motion Circuits - each motion lever on the transmitter (B, T(1), H(1)) has respectively labeled output circuitry which provides:

1. Separate common (X1) for each motion.
2. Direction outputs maintained through full-throw of switch in the respective direction.
3. Separate ‘Lo’ contacts for each direction of Hoist. These open at 2nd step.
4. Separate 2nd contacts for each direction of Hoist. These close at 2nd step.
5. 3rd, 4th, and 5th outputs close respectively and cumulatively..

- 4.4.4 Auxiliary circuits* - ‘Aux 1’ & ‘Aux 2’ have separate commons (X1), having separate output contacts and terminals, for both normally open (N.O.) and normally closed (N.C.) contacts.

* See “Options” Appendix.

4.5 INTERFACE LOGIC PANELS

4.5.1 Required uses:

4.5.1.1 Contactor control voltage exceeds 120 VAC (cab masters are often full voltage) - See 4.5.2.

4.5.1.2 Contactors larger than size NEMA 4, or multiple contactor coils are simultaneously operated.

4.5.1.3 Contactors with DC coils are used.

4.5.2 Upgrading Contact Rating

4.5.2.1 When voltage or current rating of output contacts is insufficient to operate a contactor directly, an interposing relay must be used.

4.5.2.2 The coil of the interposing relay used should be operable within the output contact ratings:

120 VAC, maximum size NEMA 4 contactor.

4.5.3 Logic Expanding

4.5.3.1 When more than one contact closure per output is required or additional logic through combinations requires more output contacts than available at the terminal strip, additional contacts must be made available through the use of interposing relays.

4.5.3.2 The addition of a logic panel can also simplify pendant, pushbutton, or cab master wiring. Assure isolation of all operating modes by the application of the Transfer Switch. Equipment control circuits may vary greatly. Control connections should be carefully considered to provide proper operation and avoid feedback circuits.

4.6 START-UP PROCEDURE

4.6.1 Before Power-up Check List:

- 1. Cabinet mounted per Outline Drawing and Manual paragraph 4.2
- 2. All conduit entry thru gland plate on bottom of cabinet.
- 3. Receiving Antenna must be visible from operating area, in all directions and over entire range of operation with Antenna* mounted vertically pointed down.
- 4. Internal components and connections are tight and secure.
- 5. Channel(s) for transmitter(s) to operate unit are selected on the Scanning Control Receiver. See tag(s) on transmitter(s) for frequency & channel.
- 6. Transfer Switch, if used, is in "Radio".

4.6.2 Receiving Power-up Check List: (Transmitter off)

- 1. With "On/Off" Rocker Switch to "On" position, turn on supply-power to radio (and control-voltages of crane). Measure 100 to 140 VAC between radio terminals 'X1' & 'X2'.
- 2. Smoke Test: Press Rocker Switch to "On" position. Neon Indicator, next to Rocker Switch, lights and Control Receiver scans thru all selected channels continuously.
- 3. Airwave Check: With squelch full clockwise, turn up volume on Control Receiver. Listen for any signals present on selected operating channels. Pure "hissing" is a welcome sound! Anything else indicates possible competition on that frequency.

* See "Options" Appendix

4.6.3 Operational Check List:

- 1. Perform system Functional Test (5.2.3.4) on Manual page 5-5 using Operating Procedure (2.3 on Manual Page 2-1); ALL functions, even if not used on this application.

- 2. Range Test:

Employing proper safety precautions, operate from the extreme locations in the area.

- 3. Show & Tell everyone who will listen!

- 4. Leave the Operation & Maintenance Manual on-site, since it will be what is needed when it is needed and where it is needed!

1.6.4 Problems

See Section 5 in the Operation & Maintenance Manual. If perplexed, call the Robinson Engineering factory from on-site. Have serial number of unit and Manual ready!

SECTION 5

MAINTENANCE

The system is of modular design, with plug-in type electronic sub-assemblies and readily replacing electrical components. Trouble can be corrected by locating and replacing the defective part. Using the substitution method. It is suggested that spare parts be obtained for replacement purposes. Field repair of electronic sub-assemblies is not recommended. Improper techniques can result in damage to components and voiding of warranty. The factory will provide prompt test and repair or replacement of returned defective or questionable parts, including the complete transmitter, at nominal cost, or at no cost under warranty. Federal Communications Commission Rules and Regulations require that tuning adjustments on the radio frequency (RF) portion of the transmitter be made only by a properly licensed person.

5.1 PREVENTIVE MAINTENANCE

No preventive maintenance is required except for periodic inspection for security of hardware, harnessed internal wiring and to check for intrusion of dirt or foreign matter. Relay contacts may be checked for excessive arcing by cycling through all motions. Replace parts as necessary.

5.2 CORRECTIVE MAINTENANCE

5.2.1 General - In case of suspected Radio Remote Control System trouble, activate the back-up controls and check for normal machine operation. If back-up system operation is not normal, locate and correct trouble in basic equipment before proceeding to radio equipment.

5.2.2 Transmitter - (See Block Diagram, Transmitter, Fig. 3-1, and Transmitter Components Fig. 5-1).

5.2.2.1 Replaceable Batteries* - Battery voltage may be measured at the LH terminals of the top two cells (top cell +, next cell -). If the voltage is less than 4.5 volts with transmitter on (Key switch on, "Start/Reset, ON, Off" Toggle Switch ON) batteries should be replaced.

5.2.2.2 Transmitter Test - A simple qualitative check of transmitter operation may be made by monitoring the receiver. A normal signal will exhibit a characteristic 25-Hertz “motorboat” sound in the Receiver speaker due to the 25 Hz. Pulse modulation. Failure to quiet receiver noise indicates no transmitter output. Receiver quieting, but without presence of modulation, indicates RF output, but defective transmitter coder.

CAUTION: When the Master Relay (and Main Contactor) is energized, any energized motion relay will cause crane motion.

5.2.2.3 Multiple System Applications - A transmitter may be converted from operation of one unit to another by changing the Address Plug installed in the transmitter. The unit to be controlled must have the proper receiver frequency channel activated. Each transmitter frequency is marked on the frequency control crystal.

Access to the interior of the transmitter is made by removing the two Phillips head screws retaining the aluminum back plate and removing the back. Figure 5-1 shows internal arrangement of parts. Removing two nylon thumbnuts and the plug retainer may access Address Plugs.

Releasing the two card guide locks and carefully sliding the assembly from the guides can remove the electronics assembly, consisting of the Junction Board, Coder Assembly and RF Assembly. The Coder and RF Assemblies are connected to the Junction Board electrically and mechanically by two connectors oriented perpendicular to the boards. They are further retained by the long 4-40 machine screws.

CAUTION: In replacing the Electronics Assembly in the case, use care to lift the two antenna spring contacts over the case bottom on insertion to prevent damage to the contacts.

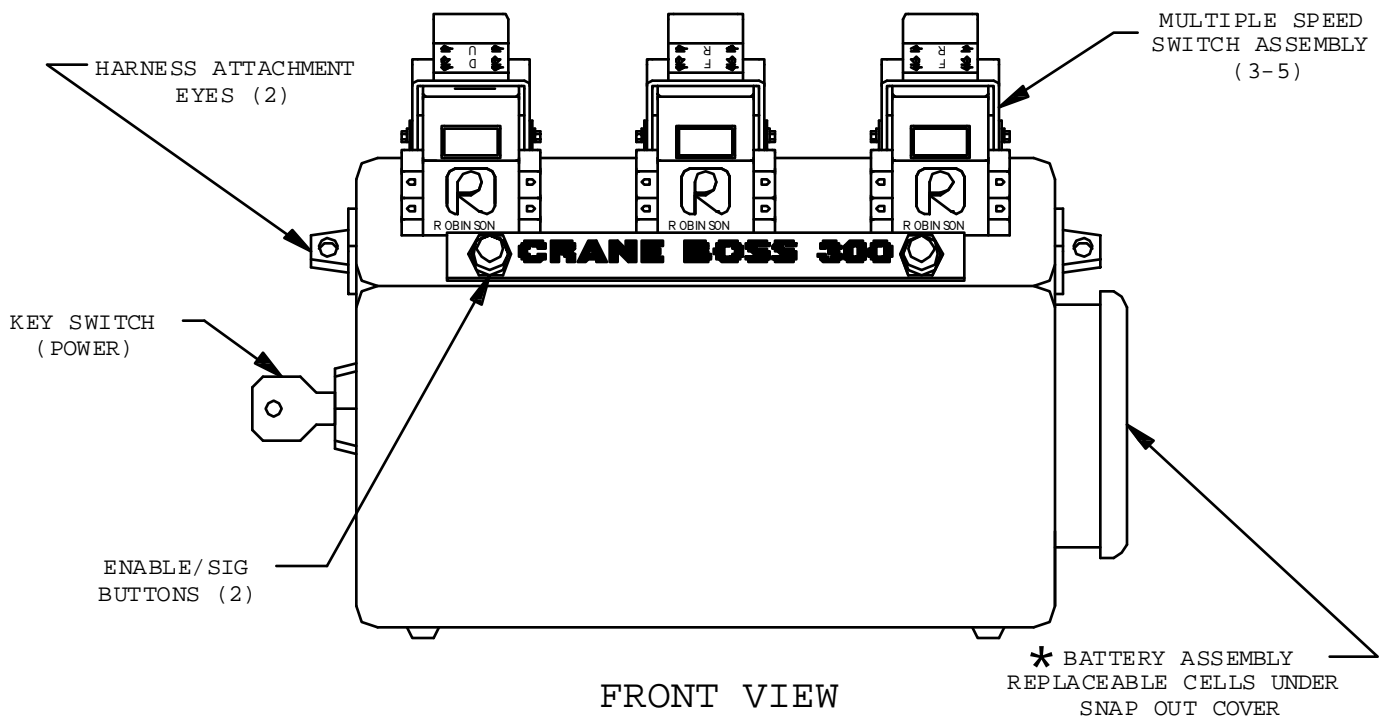
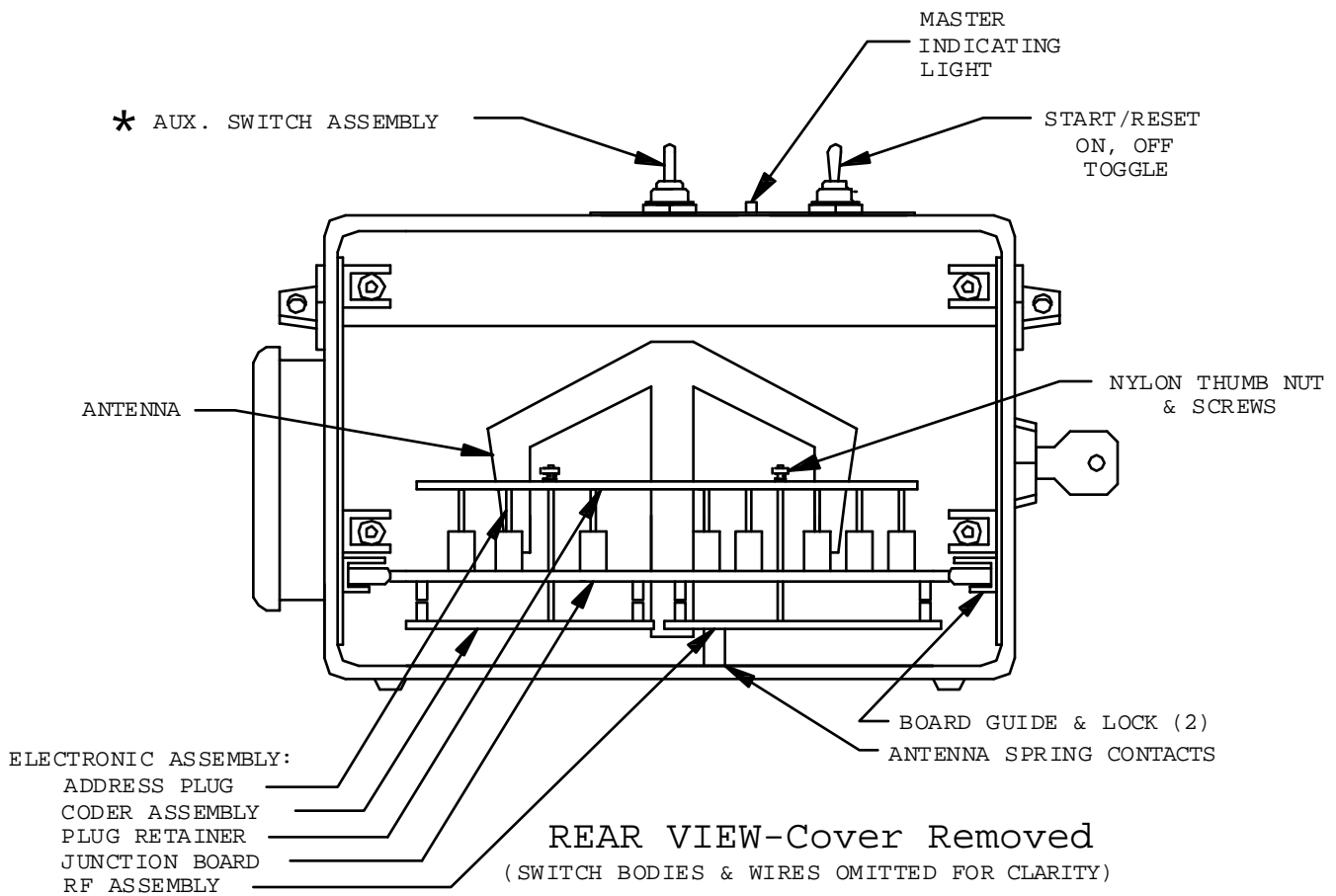

FIG 5-1: TRANSMITTER COMPONENTS
 (SHOWN WITHOUT SWITCHGUARD ATTACHED)

5.2.3 Receiving Equipment – The receiving equipment consists of a Receiver, a Controller, a Decoder and miscellaneous components (transformer, antenna, enclosure, etc.).

5.2.3.1 Receiver – The transmitter command signals transmitted to the Receiver are processed by the Receiver and are conducted to the Decoder via the Receiver Cable and the Controller board. The Decoder will return a command to the Receiver to lock onto a radio RF channel from which a valid address code has been received.

5.2.3.2 Decoder – The Decoder contains the DC power supplies and the logic processing circuits to convert the signals from the Receiver into output signals to drive the required relays. All of the relays on the Controller except the Master Relay are operated directly from the Controller.

5.2.3.3 Controller – The Controller contains the relays and terminal strips to provide isolation circuits to the Crane Controls. Each of the relays has an indicating light (LED and dropping resistor parallel to its coil to provide an indication of the operation in progress.

WARNING: The set of DIP switches next to the Decoder connection are used to set the Receiving equipment Address at the factory. DO NOT attempt any alteration!

CAUTION: Keep fingers off of the board!

CAUTION: Keep fingers off of the fuse!

CAUTION: Use extreme care when probing the board with voltmeter probes, etc.!

MAINTENANCE CHECKS

CAUTION: MAKE CERTAIN THAT THE POWER SWITCH IS ‘OFF’ WHILE PLUGGING OR UNPLUGGING, CONNECTING OR DISCONNECTING ANY COMPONENT. Non-observance may result in damage and void the warranty.

CAUTION: When the Master Relay (and Main Contactor) is energized, any energized motion relay will cause crane motion.

Refer to Block Diagram, Fig. 3-2 and Schematic, Controller, to assist in tracing trouble.

5.2.3.4 System Functional Test -

CAUTION: REMOVE MASTER WIRING BEFORE PERFORMING THIS TEST TO AVOID INADVERTENT CRANE MOTION. This test is performed with Transmitter in view of the Controller so that the LED indicators and relays may be observed. Have all modules in place, Transfer Switch in “Radio” and Power Switch “On” (Neon Indicator lit).

	<u>Action</u>	<u>Anticipated Result</u>
1.	Turn Transmitter “On” (Key switch and “Start/Reset, On, Off” Toggle).	Address relay will operate observe indicator).
2.	Depress either Enable/Sig pushbutton.	Enable Relay will operate momentarily until push-button is released. (Observe indicators). Master relay indicator will light momentarily also.
3.	Operate “Aux” switch* to “1” and “2” in turn.	“Aux” “1” and “2” relays will operate.
4.	Operate motion switches	Each function relay is energized forward (down) and reverse (up) in turn. 2 nd , 3 rd , 4 th & 5 th speeds energize in either direction.

* See “Options” Appendix

If any relay and its LED indicator fail to operate, replace the Decoder.
(See "CAUTION", top of Page 5-5).

This test provides an opportunity to observe the relays operate mechanically and an opportunity to detect a defective relay. It may also be used as an aid in locating problems in the output circuits to the crane.

NOTE: If step 1 does not provide any of the indications noted and all voltage checks of paragraph 5.2.3.5 are correct, replace the Address relay. (See 'CAUTION', top of Page 5-5).

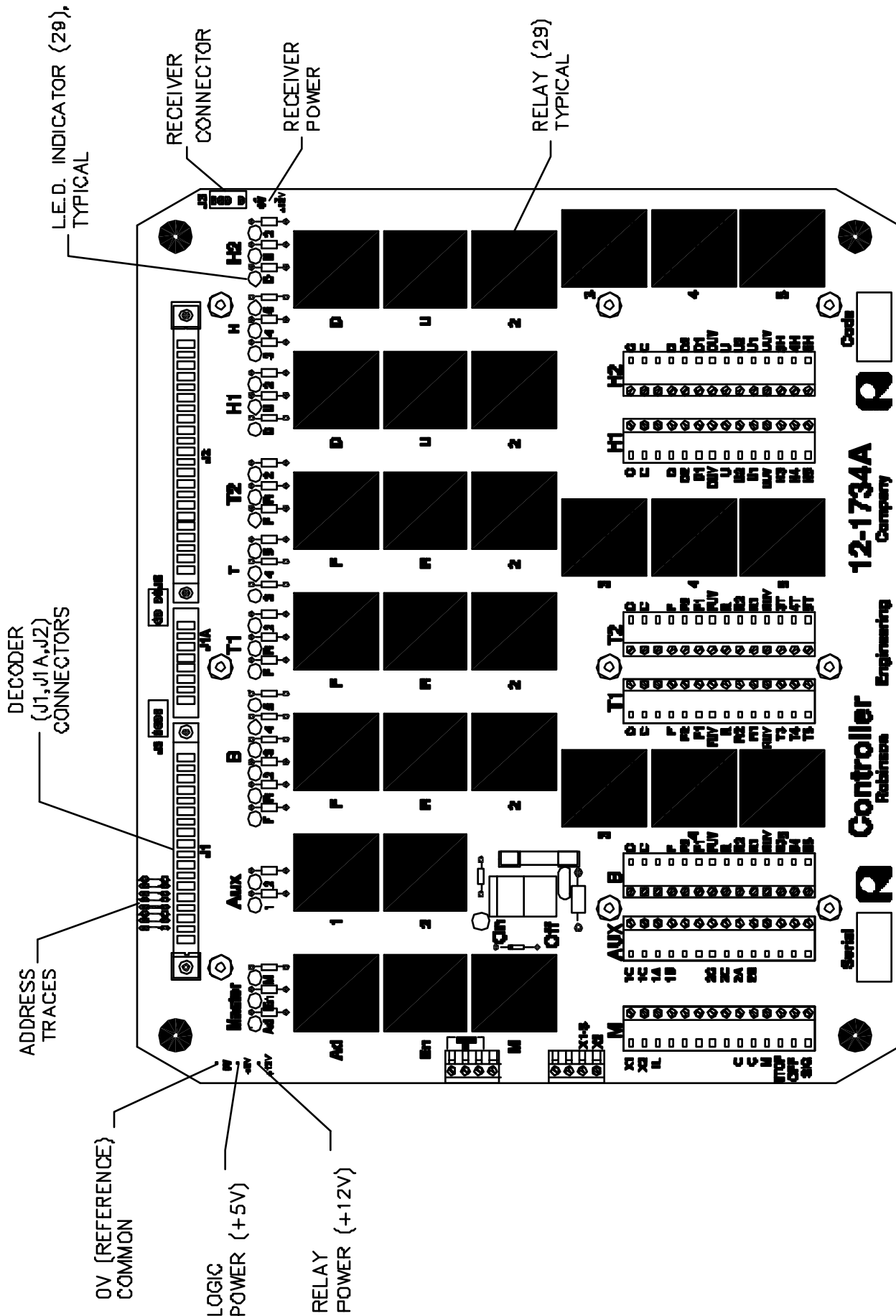

FIG. 5-2 (L)

5.2.3.5 Voltage Checks:

<u>Test Points</u>	<u>Voltage</u>	<u>Test for</u>
Terminals “X1”, “X2”	117 VAC	<u>Input power</u>
Terminals “117 VAC”	117 VAC (Neon indicator lighted)	Power <u>switch</u> ”ON”, <u>Fuse OK</u> .
Terminals “24 VAC” (2) and “CT”	24 VAC between designated Terminals), 12 VAC between “CT” and each of the above terminals.	<u>Transformer</u> Output.

If any of the above checks fail to provide the noted voltage reading, the component involved should be repaired or replaced. (See “CAUTION”, top of Page 5-5).

Controller board OV and +5V (left and above “Ad” relay)*	5 ± .2 VDC	Decoder 5 VDC logic power
Controller board OV and relay +12V (left and above “Ad” relay).*	15 to 18 VDC no load. 9.5 to 11.0 VDC under max. relay load.	Decoder 12 VDC Power
Controller board OV and +12 VDC (below receiver connector).	15 to 18 VDC	Decoder 12 VDC Receiver power

- * Note:
- 1) Transformer may need to be loosened from mounting.
 - 2) The type of meter used will vary the “no load” readings considerably.

If any of the above checks fail to provide the noted voltage readings, The Decoder should be replaced. (See “CAUTION”, top of Page 5-5).

5.2.3.5 Receiver – use the Transmitter qualitative test, paragraph 5.2.2.2 to check the Receiver. If receiving range appears to be reduced, check antenna for defects and proper connections.

NOTE: The cable connecting the Receiver to the Controller should not be ignored. A continuity test may be appropriate. (See “CAUTION”, top of Page 5-5).

5.2.3.7 Decoder – The only check for a suspected defective Decoder is substitution of a spare module.

5.2.3.8 Controller – Refer to Schematic, Controller, for assistance in circuit tracing.

CAUTION: When the Master (and Main Contactor) is energized, any energized motion relay will cause crane motion.

With Transmitter “OFF”, all relays (and LEDs) should be de-energized.

Main Circuit – This circuit is designed to operate in the following sequence:

1. Transmitter “Off”, all relays de-energized.
2. Transmitter “ON”, Address and Enable relays energized.
3. Address and Enable relays energize Master Relay (M) if all Transmitter motion controls are “OFF”. Address relay must be energized before any other function relay may be energized.
4. De-energizing the Address Relay by turning the Transmitter “OFF” de-energizes the Main Contactor, Enable and Master relays.

Relay contact circuits only control the Master Relay. An examination of the Schematic will reveal a series of normally closed circuits. If any of these relays are energized, the circuit will open, not allowing the master relay to energize.

This is also true if any of these relays are missing or have a defective contact.

Also note, if the Address and Enable relays are not energized, the Master Relay cannot energize.

Safety Circuit - This circuit is a comparison circuit between the Address relay and the Enable relay condition providing for a system shut down in the event of a mis-match of more than a fraction of a second duration.

5.3 REPLACEABLE PARTS

When purchasing parts from the factory, please provide the Serial Number of your equipment (See nameplate on Transmitter or Receiving Equipment).

	<u>Quantity/ System</u>	<u>Quantity Spare Parts</u>	<u>Recommended Spares Kit</u>
5.3.1 Transmitting Equipment:			
Transmitter, Model 300 L	1	1	
Shoulder Harness	1		
Battery Cover Assembly	1	1	
Multiple Speed Switch Assembly	3		
Aux Switch Assembly*	0 – 1		
With Boot			
Boot only			
5.3.2 Receiving Equipment:			
Control Receiver	1	1	1
Receiver Cable	1		
Antenna Cable	1		
Antenna	1		
Decoder	1		
Relay, <u>12 VDC</u> , Mini 10A	23		
Retainer	23		
Fuse, 8 AG-2A	1		
(not instrument rating)			
Transformer, 117/24V (CT)	1		
(50 VA)			
Controller	1		
(Relay PC Assembly)			
with Relays*			

5-11

* Need Transmitter Serial Number

INDEX

Adjustments; Frequency,	5. / page 5-1
Antenna; Receiving; Installation,	4.2.4/ page 4-2 & 4.6.1 / page 4-7
Remote,	4.2.4.1 / page 4-2
Battery; Voltage,	5.2.2.1 / page 5-2
Coding; Address,	1.2.3 / page 1-2
Address,	3.1 / page 3-1
Address,	3.3.4 / page 3-6
Address,	5.2.2.3 / page 5-2
Frequency; Adjustment,	5. / page 5-1
Carrier,	3.1 / page 3-1
Marked,	5.2.2.3 / page 5-2
Scanning,	3.3.2 / page 3-5

INDEX (Continued)

Operating; Abnormal,	2.4 / page 2-2
Multiple System,	3.1 / page 3-1
Multiple System,	5.2.2.3 / page 5-2
Normal,	2.3 / page 2-1
Transmitter,	2.2 / page 2-1
Transmitter,	5.2.2.3 / page 5-2
Output; Contact Rating,	3.3.5 / page 3-6
Contact Rating,	4.5.2 / page 4-6
Contacts,	4.4.2 / page 4-5
Indicating Light,	4.2.3 / page 4-1
Logic Expanding,	4.5.3 / page 4-6
Power; Incoming A.C.,	4.2.5 / page 4-2

Crane Boss 300K

TROUBLESHOOTING INDEX

0. GENERAL

BACK-UP: 5.2.1

FAILSAFE: 1.2.3(2.), 2.3.7, 2.4

MODULARITY: 1.2.1(6.), FIG. 3-1 & 3-2, FIG. 5-1 & 5-2K

INTERCHANGEABILITY: 3.2 & 3.3, 5.2.2 & 5.2.3

POWER SUPPLY: 2.1, 3.3.3, FIG. 4-1, 5.2.3.5

CODE: 1.2.3(4. & 7.), 3.1, 3.3.4, 5.2.2.3, 5.2.3.3, FIG. 5-2K

I. TRANSMITTING & RECEIVING

BATTERY: 1.2.4, 5.2.2.2

OPERATION: SECTION 2, 3.1

FREQUENCY(S): 1.2.3(7.), 2.4(3.), 3.1, 3.2, 3.3.2, 4.6.1(5.), 4.6.2(3.)

SIGNAL(S): 3.2, 3.3.2, 5.2.2.2, 5.2.3.1

UNIVERSAL: 2.3(3.), 3.2, 5.2.2.3

ALL-STOP: 2.3(7.), 2.4, 3.1, 5.2.3.8

RECEIVING: 3.3.2, 5.2.2.2, 5.2.3.1

FIELD ADJUSTMENT: 1.2.3(6.), 3.3.2, 4.6.3(2.), 5.2.3.6

ANTENNA: 3.3.1, 4.2.4, 4.6.1(3.), 5.2.3.6

II. (EN)CODING & DECODING

ADDRESS: 1.2.3(7.), 2.3(3.), 3.1, 3.2, 3.3.2, 3.3.4, 5.2.2.3, 5.2.3.3, 5.2.3.8

“DRY RUN”: 5.2.3.4

DECODING: 3.3.3, 5.2.3.7

III. SAFETY & SEQUENCE

OPERATION: 2.3(5.), 2.4

SIGNAL(S): 3.3.5, 5.2.3.8

MASTER: 2.3(5.), 2.4, 5.2.3.8

IV. INPUTS & OUTPUTS

SWITCHES: 2.3(5. & 7.), 5.2.3.4

RELAYS: 3.3.5, 4.4.2, 4.4.3, 4.5, 5.2.3.4 & FIG. 5-2K

RELAY CIRCUITS: 1.2.3(5.), 1.2.4, 4.4, 4.5, 5.2.3.8

OUTPUT CIRCUITS: FIG. 4-1 & 4-2K

OPTIONS

* Variances per Option

- 1.2.2 “Functions” (1-1), see 2- & 3- Position Aux.
- 1.2.4 “Battery” (1-3), see Rechargeable Battery Pack & Charger.
- 2.2 “Transmitter stored” (2-1), see Rechargeable Battery Pack & Charger.
- 2.3 “Transmitter stored” (2-2), see Rechargeable Battery Pack & Charger.
- 3.2 “Batteries” (3-2), see Rechargeable Battery Pack & Charger.
- 3.2 “Address” (3-2), see Multi-crane.
- 4.2.4.1 “Antenna” (4-2), see Remote Antenna Kit.
- 4.4.4 “Auxiliary Circuits” (4-5), see 2- & 3- Position Aux.
- 4.6.1 “Antenna” (4-7), see Remote Antenna
- 5.2.2.1 “Battery” (5-5), see Rechargeable Battery Pack & Charger.
- 5.2.3.4 “Master Relay” (5-5), see 2- & 3- Position Aux.
- 5.2.3.8 “Master Relay” (5-10), see 2- & 3- Position Aux.
- 5.3.1 “Aux Switch Assembly” (5-11), see 2- & 3- Position Aux.
- 5.3.2 “Controller” (5-11), see 2- & 3- Position Aux.

OPTIONS

Available Options:

3-Position Aux, “#1/(OFF)#2”: A 3-position Momentary switch on the Transmitter.

Center Position = Both ‘Aux 1’ & ‘Aux 2’ “OFF”

3-Position Aux, “#1/Both/#2”: A 3-position maintained switch on the Transmitter. Also, Master Relay circuit on Controller is revised accordingly.

Center Position = Both ‘Aux 1’ & ‘Aux 2’ “ON”

2-Position Aux, “#1/#2”: Similar to 3-position Aux, but 2-position maintained switch: Either ‘Aux 1’ is “ON”, or ‘Aux 2’ is “ON”. Also, Master Relay circuit on Controller is revised accordingly.

Multi-Crane: Allows one Transmitter to operate up to six (special cases, eight) cranes, each one-at-a-time. This variable address switch is a key lock. Note that the Transmitter does not change its frequency!

OPTIONS

Rechargeable Battery Pack & Charger:

Battery power supply is of the rechargeable type. Recharge is accomplished by plugging charger cord in Battery Pack and connecting charger to standard 115 volt 60 cycle convenience outlet. Full charge is accomplished in 12 hours. Battery pack is removable. Recharge can be done with battery installed or removed from transmitter.

Battery voltage may be measured at the “banana jack” terminals. Red terminal is positive, black negative. A full charged battery should provide 5.4 ± 0.4 volts. If battery is in discharged state, connect voltmeter and observe reading when battery charger is connected. The battery voltage should rise to a value not less than 5.0 volts and not more than 5.8 volts within the first minute of charging time. After one minute of charging, disconnect charger. Voltage should remain stable in excess of 5.0 volts. Readings outside these limits indicate a defective battery pack.

Battery Charger - “Power” and “Charge” lights should provide normal indication. The open circuit voltage measured between pins A and B of the charging connector should be 12 volts D.C. with no battery connected. Short circuit current should be 330 milliamperes with current meter connected to A and B. Pin A is positive, B negative. If indication is abnormal, replace charger.

When Transmitter is not in use, charging of the Battery Pack is allowed and highly recommended.

OPTIONS

Remote Antenna Kit:

Mounting of the Receiving enclosure should allow for the Antenna to be:

1. Clear of large metal objects, bring greater than one foot away from bridge girders, hoist mechanism, etc;
2. In view from the entire operating area, in all directions;
3. And not in close proximity to crane electrification, like runway conductors, bridge cross conductors, festooning, conduit or wire way.

If any of these conditions cannot be met, a Remote Antenna Kit should be used.

The Kit includes 10 ft. of add-on cabling with Antenna mounting plate attached and base for the plate.