

# ROBINSON ENGINEERING COMPANY

## Operation & Maintenance Manual

# Crane Boss®

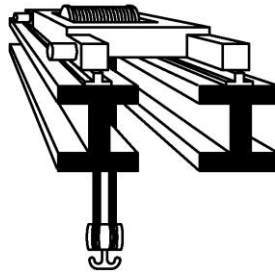

## Digital Radio Remote Control

January, 2017

## TABLE OF CONTENTS

|           |                                     | PAGE |
|-----------|-------------------------------------|------|
| SECTION 1 | GENERAL INFORMATION                 |      |
| 1.1       | SCOPE                               | 1-1  |
| 1.2       | SYSTEM DESCRIPTION                  | 1-1  |
| 1.3       | GUARANTEE                           | 1-4  |
| SECTION 2 | OPERATION                           |      |
| 2.1       | RECEIVING EQUIPMENT                 | 2-1  |
| 2.2       | TRANSMITTER                         | 2-1  |
| 2.3       | OPERATING PROCEDURE                 | 2-1  |
| 2.4       | MISCELLANEOUS OPERATING INFORMATION | 2-3  |
| SECTION 3 | PRINCIPLE OF OPERATION              |      |
| 3.1       | TRANSMITTER                         | 3-1  |
| 3.2       | RECEIVING EQUIPMENT                 | 3-3  |
| 3.3       | DIGITAL CODE FORMAT                 | 3-6  |
| SECTION 4 | INSTALLATION INFORMATION            |      |
| 4.1       | GENERAL                             | 4-1  |
| 4.2       | APPLICABLE DRAWINGS                 | 4-1  |
| 4.3       | CRANE FUNCTION CONTROL              | 4-1  |
| 4.4       | OPERATING FREQUENCIES               | 4-2  |
| 4.5       | ADDRESS CODE                        | 4-2  |
| SECTION 5 | MAINTENANCE                         |      |
| 5.1       | PREVENTIVE MAINTENANCE              | 5-1  |
| 5.2       | CORRECTIVE MAINTENANCE              | 5-1  |
| 5.3       | REPLACEABLE PARTS                   | 5-13 |

## TABLE OF FIGURES

| FIGURE | TITLE                              | PAGE |
|--------|------------------------------------|------|
| 3-1    | BLOCK DIAGRAM, TRANSMITTER         | 3-2  |
| 3-2    | BLOCK DIAGRAM, RECEIVING EQUIPMENT | 3-5  |
| 5-1    | TRANSMITTER COMPONENTS             | 5-3  |
| 5-2M   | CONTROLLER                         | 5-9  |

## SECTION 1

### GENERAL INFORMATION

#### 1.1 SCOPE

This manual contains information necessary to install, operate and maintain Crane Boss II Radio Remote Control Systems. The information is generally applicable to all Crane Boss systems manufactured by Robinson Engineering Company. Data which are unique to the particular system for which this manual is furnished are given in Section 4.

#### 1.2 SYSTEM DESCRIPTION

1.2.1 General - The system is equipped with controls and accessories required for reliable electrical operation of a crane or other machinery from a portable wireless control transmitter. Control functions are provided to meet the particular requirements of each application.

Characteristic features are:

1. Each system consists of a portable control transmitter which operates in conjunction with receiving equipment installed on the crane structure and electrically connected to the crane magnetic controllers.
2. "Fail-safe" circuits are used throughout the system.
3. The command link is capable of handling all motions simultaneously.
4. The system uses digital pulse code frequency modulation. It was developed specifically for industrial control.

5. The system utilizes fully solid state electronic circuits, with heavy duty relay contact output circuits.
6. Maintenance requirements are greatly reduced by modular design and use of digital switching circuits. No special test equipment is required.
7. Radio control of several cranes in the same plant without interference is entirely practical. Each transmitter transmits a unique address code, which prevents response by other than the intended unit. In addition, the operating frequencies of different units are staggered within the frequency band to prevent interference. Proper selection of address codes and operating frequencies with respect to physical separation provides control of multiple installations with no practical limitation on the number at one location.

1.2.2 Transmitter - The transmitter is a portable Unit which is carried by the operator. A shoulder harness is provided to enable the operator to conveniently carry the unit while leaving hands free to operate controls. Switches on the transmitter control all functions as labelled.

The portable transmitter weight is approximately 4.7 pounds. The transmitter includes internal antenna and battery pack. Battery is charged from standard AC wall outlet by means of a battery charger. Battery will provide 16+ hours of continuous operation between charges. Full charging requires 2 to 3 hours. A transmitter with one battery pack can be operated continuously 16 hours per day and recharged in 2 to 3 hours. Continuous "around the clock" operation can be accomplished by use of a spare battery pack, with one pack in use while the other is charging.

1.2.3 Receiving Equipment - The receiving equipment cabinet is mounted on the machinery and contains the radio receiving unit, decoding equipment and relays to convert the radio signal from the transmitter to signals suitable for operation of (magnetic) controls' contractors.

### 1.3            GUARANTEE

Manufacturer warrants the delivered remote control system to be free of defective material and workmanship and agrees to remedy any such defect within two years of first party purchase at no charge to the purchaser upon return of defective parts to factory. Defects cause by improper installation, maintenance, misuse, tampering, neglect, accident, or use in violation of manufacturer's written instructions shall not be covered by this warranty. Manufacturer guarantees that remote control system will perform as outlined in this manual.

Transferring of this warranty is acceptable and recommended. Please notify this factory of any and all transfers.

## SECTION 2

### OPERATION

#### 2.1 RECEIVING EQUIPMENT

Normal operating procedure is to leave receiving equipment energized at all times. (Power switch "On", neon indicator lighted). The unit can then be readily placed in operation by means of the portable control transmitter.

#### 2.2 TRANSMITTER

The transmitter should be stored in an assigned location when not being used to operate the crane. During idle periods, the "EMO" switch should be actuated to de-energize the Mainline Contactor. The battery should be removed and placed on the battery charger; maintaining full charge will result in longer battery life. Battery capacity will allow 16+ hours of continuous operation without recharging. Full recharge can be accomplished in 2 to 3 hours.

#### 2.3 OPERATING PROCEDURE

To place the unit in operation, proceed as follows:

1. Make sure the Datakey is inserted in the receptacle in the battery compartment. The transmitter is designed not operate without a valid Datakey.
2. Insert the battery into the battery compartment.
3. Operator should be in a position so as to have a clear view of the motions and actions.
4. If multi-crane unit is being used, make certain the proper Datakey is inserted.
5. With all operating controls in neutral position, rotate the "EMO" Switch so that it is disengaged.



6. Before pressing the green "Start" pushbutton the Green LED will be solid green. The solid green means the transmitter EMO is de-energized and is ready to transmit. This is a standby mode. After pressing the green pushbutton, the transmitter switches to transmit mode and starts transmitting. The Address relay will turn on at this point. Pressing the green "Start" button "again" will energize the Enable Relay in the receiver. At this point if all function switches are in neutral, the Master Relay will latch on in the receiver. The transmitter Green LED will flash rapidly regardless of the Master Relay state. The rapid flash indicates the transmitter is going through its various internal states and reading all available user inputs.
7. Crane can now be moved by operating desired control levers. The direction and speed of motion will be determined by direction and distance control levers are deflected. All motion controls are spring loaded to neutral so that "hands off" condition will stop the crane.
8. In the event of an emergency situation, immediately press the "EMO" mushroom button. On pressing the EMO button, the transmitter will transmit a "clear payload" signal to the receiver. Once the receiver receives this signal, the decoder shall de-energize the Master relay.
9. Upon completion of lift, restore crane to proper parking position and press the "EMO" mushroom button. Replace transmitter in designated storage location and remove the battery and place it on the charger.
10. The rechargeable battery pack is must be removed from the transmitter in order to be charged. For applications which require continuous "around the clock" operation, one battery pack can be in use while a second is on charge, and the two battery packs interchanged daily.
11. There are four LED indicators, labeled 1, 2, 3 & 4. These indicators can be configured for your application. LED1 and LED2 are used to indicate an active Trolley and/or Hoist Select or any function that is maintained. LED3 and LED4 have a dual purpose. If LED3 or LED4 are solid red then this is used to indicate an active Trolley and/or Hoist Select or any other function that is maintained. If LED3 is blinking red then that indicates a low battery. If LED4 is blinking red, this indicates various internal errors. Some of the errors are:
  - (1) Invalid data in the Datakey.
  - (2) Internal communication error among various components inside the transmitter.

## 5.2 MISCELLANEOUS OPERATING INFORMATION

Abnormal electrical conditions during operation will de-energize control circuits, stopping motion. This can be caused by any one of a number of abnormal conditions. Among these are:

- 5. Weak or improper radio signal.
- 5. Interruption of power to receiving equipment.
- 5. Radio interference.
- 5. Malfunction of radio equipment.
- 5. Malfunction of crane electrical equipment.

If the abnormal condition is temporary, control can be resumed by repeating steps 1. Through 6. Of paragraph 2.3. The exact sequence of operation must be followed to accomplish operation of safety circuits in the receiving equipment.

## SECTION 3

### PRINCIPLE OF OPERATION

#### 3.1 TRANSMITTER

The Crane Boss II Transmitter is a battery operated frequency modulation radio transmitter. Incorporated with the transmitter is an antenna and rechargeable battery pack. When the various switches are actuated, coded control signals are sent to the receiving equipment via the antenna. A block diagram of the transmitter is shown by Fig. 3-1.

The radio frequency signal radiated by the antenna is generated by the RF Module, and is frequency modulated by a pulse code modulation signal. This modulation signal consists of a series of synchronizing pulses determined by the position of the various function controls, which are actuated by the operator.

Variations in code format between systems is accomplished by means of factory connections on the Junction Board, by the Datakey, and by wiring to the various control devices.

In multiple system installations where control functions of the various cranes are similar, a given transmitter may be converted from control of one crane to another by changing the Datakey installed in the transmitter. The Receivers used in multiple crane installations are normally supplied with capability of receiving all transmitting frequencies used at that installation.

FCC Part 15 Contains FCC ID: NQHTRM900NTDB. This device complies with Part 15 of the FCC Rules. Operation is subject to the following two conditions: (1) this device may not cause harmful interference and (2) this device must accept any interference received, including interference that may cause undesired operation.

IC Statement IC: 4527A-TRM900NTDB. This device complies with Industry Canada license exempt RSS standard(s). Operation is subject to the following two conditions: (1) this device may not cause harmful interference and (2) this device must accept any interference received, including interference that may cause undesired operation.

EXTERNAL CONTROLS

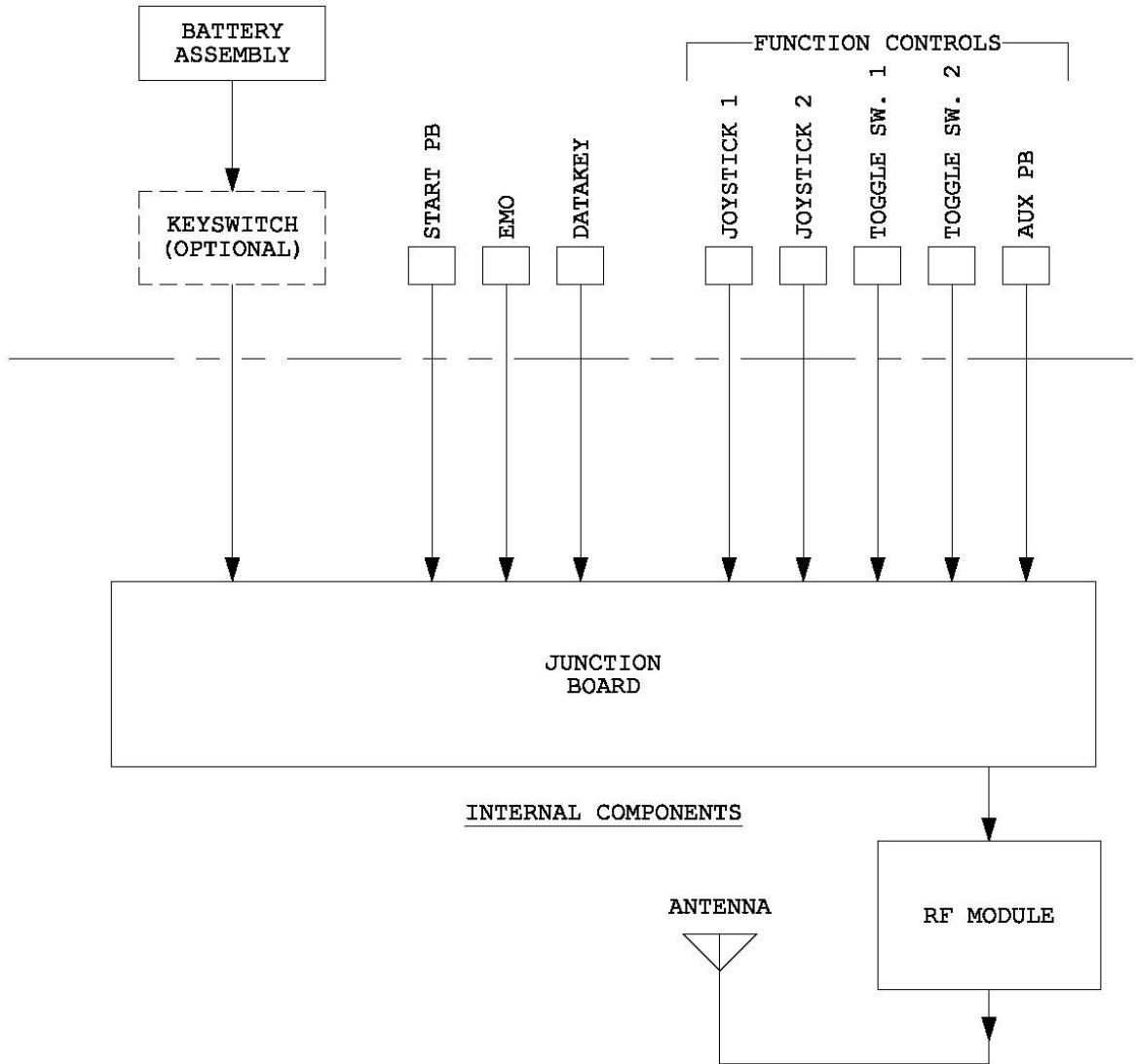

FIG. 3-1: BLOCK DIAGRAM, TRANSMITTER

## 3.2 RECEIVING EQUIPMENT

A block diagram is shown by Figure 3-2. The radio signal from the transmitter is received by the antenna, which is connected to the Receiver by coaxial cable. Receiver data output is fed to the Decoder, where it is decoded and signals suitable for operation of the output relays are generated. The output relays provide heavy duty control circuits to the basic machine electrical controllers.

3.2.1 Antenna - The Antenna is pre-tuned for the frequency band used.

3.2.2 Receiver - The Receiver amplifies and detects the frequency modulated pulse code signal and includes filtering and shaping circuits to process the signal. Data output consists of rectangular pulses of 12 volts amplitude which are a replica of the transmitter coder output.

The Receiver is a synthesized frequency controlled scanning type receiver which continuously scans all selected channels until a signal is received which contains the proper address code. When proper address code is received, scanning stops and, the receiver remains "locked-on" that channel for as long as the code remains. Channels are controlled by a dip switch. The dip switch can be turned "Off" when unused or turned "On" when other equipment is added.

3.2.3 Decoder - The receiver data output is connected to the Decoder through the Controller, where it is processed into form suitable for operation of the Relays. The Decoder also performs certain synchronization, safety interlock, digital filtering and noise rejection functions. All DC voltages originate in the Decoder.

3.2.4 Address Code - The address is a two digit hexadecimal number that is set at the factory. The number for each system is shown in the "Code" number block in the lower right corner of the Controller.

3.2.5 Output Relays - Relay contact logic circuits provide additional safety sequencing and interlocking functions. Output circuits are connected to terminal blocks for connection to magnetic controllers. Output relay circuits are rated for operation of up to NEMA size 4 contactors at a maximum coil voltage of 125 volts a.c.

3.2.6 Transfer Switch - Wiring as shown on the Interconnection Diagram allows only a mutually exclusive transfer between modes of operation. (If a back-up mode exists.)

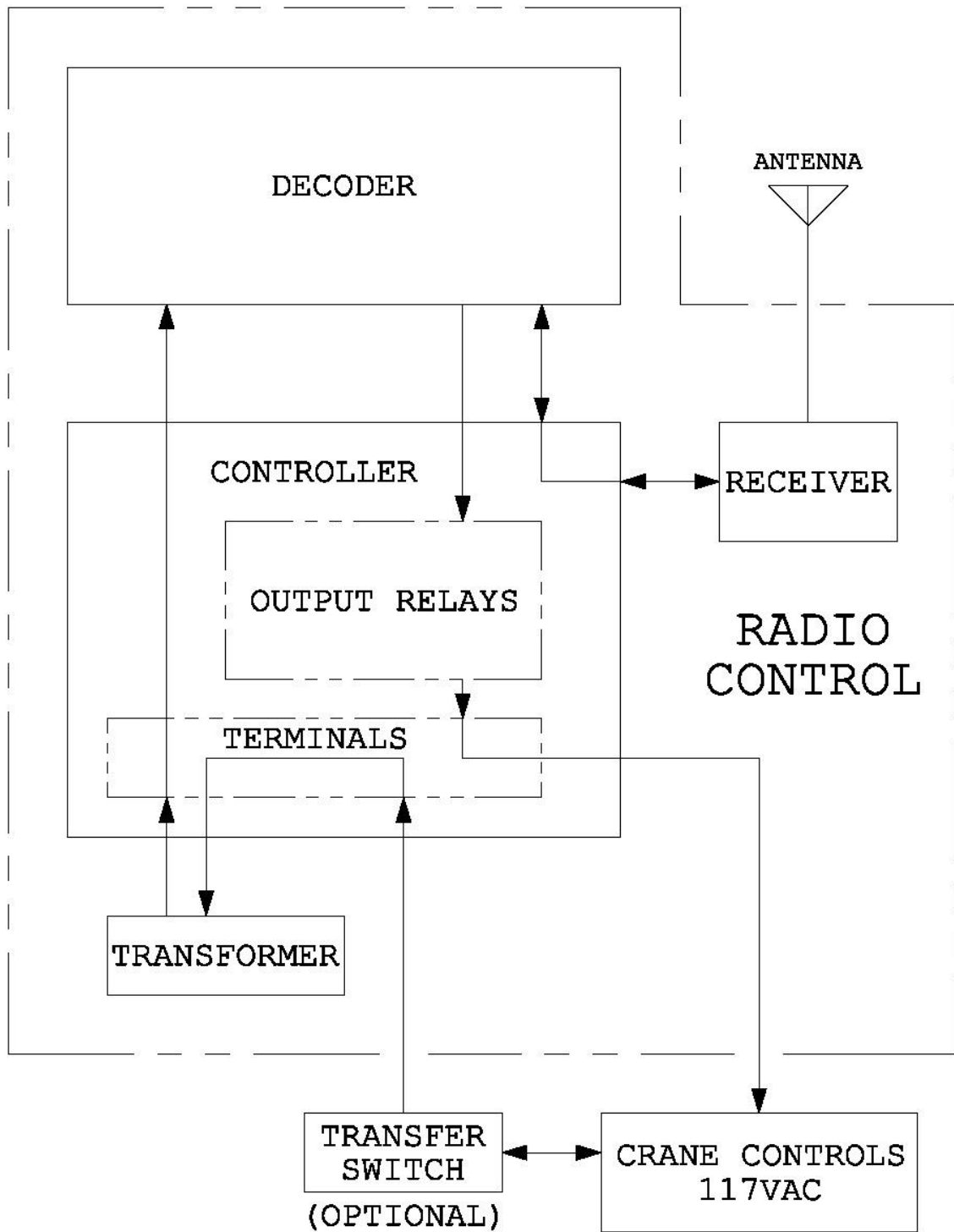

FIG. 3-2: BLOCK DIAGRAM, RECEIVING EQUIPMENT

### 3.3 DIGITAL CODE FORMAT

The digital control code, which is transmitted by frequency modulation of the transmitter, consists of a series of pulses which is repeated at a rate of 25 per second (40 milliseconds period). Each series consists of a synchronizing pulse of 4 milliseconds duration, followed by 90 spaces of 400 microseconds duration each. Each of these 90 spaces may or may not be occupied by a control pulse, depending on the control signal. Control pulses are 200 microseconds between adjacent control pulses.

For the purpose of defining the code signal, the 90 spaces are divided into nine blocks of ten spaces each. These nine blocks are identified as Block 0 through Block 8. The ten pulse spaces of each block are identified by the numerals 0 through 9. In general, one ten bit block is assigned for a particular function such as Address, Bridge, Trolley, Hoist, etc.

3.3.1 Pulse space assignments within a block for the major motions, Bridge, Trolley(s), Hoist(s), are standardized. For each function, pulses occupy the space listed.

| <u>Function (5 speeds)</u> | <u>Pulse Spaces</u> |
|----------------------------|---------------------|
| Fwd/Dn/N/E speed 1         | 1, 2                |
| Fwd/Dn/N/E speed 2         | 1, 2, 3             |
| Fwd/Dn/N/E speed 3         | 1, 2, 3, 4          |
| Fwd/Dn/N/E speed 4         | 1, 2, 3, 4, 5       |
| Fwd/Dn/N/E speed 5         | 1, 2, 3, 4, 5, 6    |
| Rev/Up/S/W speed 1         | 0, 2                |
| Rev/Up/S/W speed 2         | 0, 2, 3             |
| Rev/Up/S/W speed 3         | 0, 2, 3, 4          |
| Rev/Up/S/W speed 4         | 0, 2, 3, 4, 5       |
| Rev/Up/S/W speed 5         | 0, 2, 3, 4, 5, 6    |



### 3.3.2 Block Assignments

| <u>Block</u> | <u>Function</u>                     |
|--------------|-------------------------------------|
| 5            | None                                |
| 5            | Address & Enable<br>(see Section 4) |
| 2            | Aux                                 |
| 3            | 'B'                                 |
| 4            | 'T1'                                |
| 5            | 'T2'                                |
| 6            | 'H1'                                |
| 7            | 'H2'                                |
| 8            | None                                |
| 9            | None                                |

Each function activated separately, activates its appropriate indicator and Relay in the Receiving equipment. Every function is independent of the others, except that the Address must be energized before any other function can be decoded.

## SECTION 5

### MAINTENANCE

The system is of modular design, with plug-in type electronic sub-assemblies and readily replaceable electrical components. Trouble can be corrected by locating and replacing the defective part, using the substitution method. It is suggested that spare parts be obtained for replacement purposes. Field repair of electronic sub-assemblies is not recommended. Improper techniques can result in damage to components and voiding of warranty. The factory will provide prompt test and repair or replacement of returned defective or questionable parts, including the complete transmitter, at nominal cost; or at no cost under warranty.

#### 5.1 PREVENTIVE MAINTENANCE

No preventive maintenance is required except for periodic inspection for security of hardware, harnessed internal wiring and to check for intrusion of dirt or foreign matter. Relay contacts may be checked for excessive arcing by cycling through all motions. Replace parts as necessary.

#### 5.2 CORRECTIVE MAINTENANCE

5.2.1 General - In case of suspected Radio Remote Control System trouble, activate the back-up controls and check for normal machine operation. If back-up system operation is not normal, locate and correct trouble in basic equipment before proceeding to radio equipment.

5.2.2 Transmitter - (See Block Diagram, Transmitter, Fig. 3-1, and Transmitter Components, Fig.5-1).

5.2.2.1 Transmitter Test - A simple qualitative check of transmitter operation may be made by monitoring the receiver. A normal signal will exhibit a characteristic 25 Hertz "motorboat" sound in a speaker due to the 25 Hz. Pulse modulation. A speaker jack is provided to connect an external Speaker. Failure to quiet receiver noise indicates no transmitter output. Receiver quieting, but without presence of modulation, indicates RF output, but defective transmitter junction board.

**CAUTION:** When the Master Relay (and Main Contactor) is energized, any energized motion relay will cause crane motion.

5.2.2.2 Multiple System Applications - A transmitter may be converted from operation of one unit to another by swapping the Datakey installed in the transmitter. The unit to be controlled must have the proper receiver frequency channel activated.

Access to the interior of the transmitter is made by removing the four hex screws retaining the top and bottom halves of the transmitter. Internal arrangement of parts is shown by Figure 5-1. The Datakey may be accessed from the battery compartment.

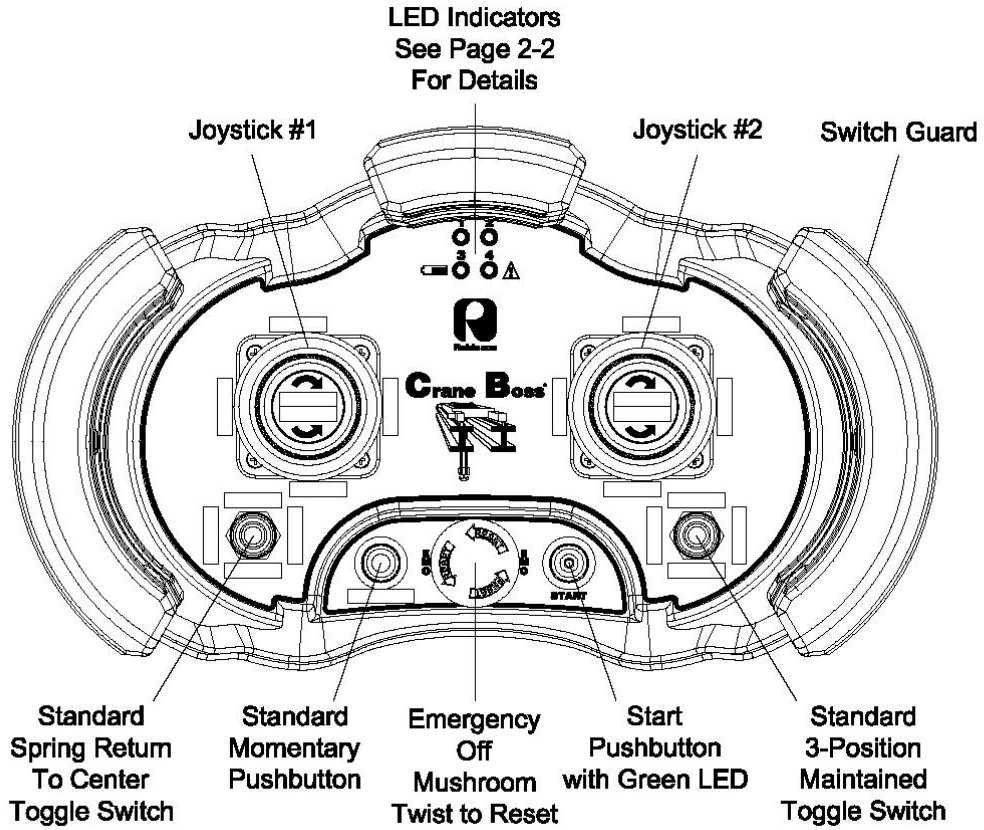

NOTE: Arrangement Varies With Application.

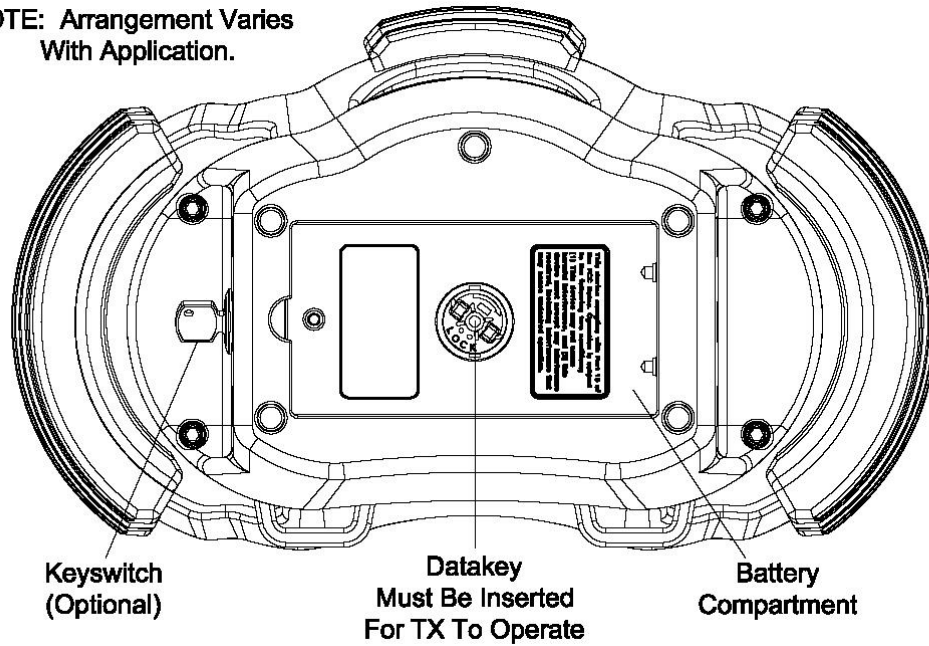

Fig. 5-1 Joystick Transmitter (External Components)

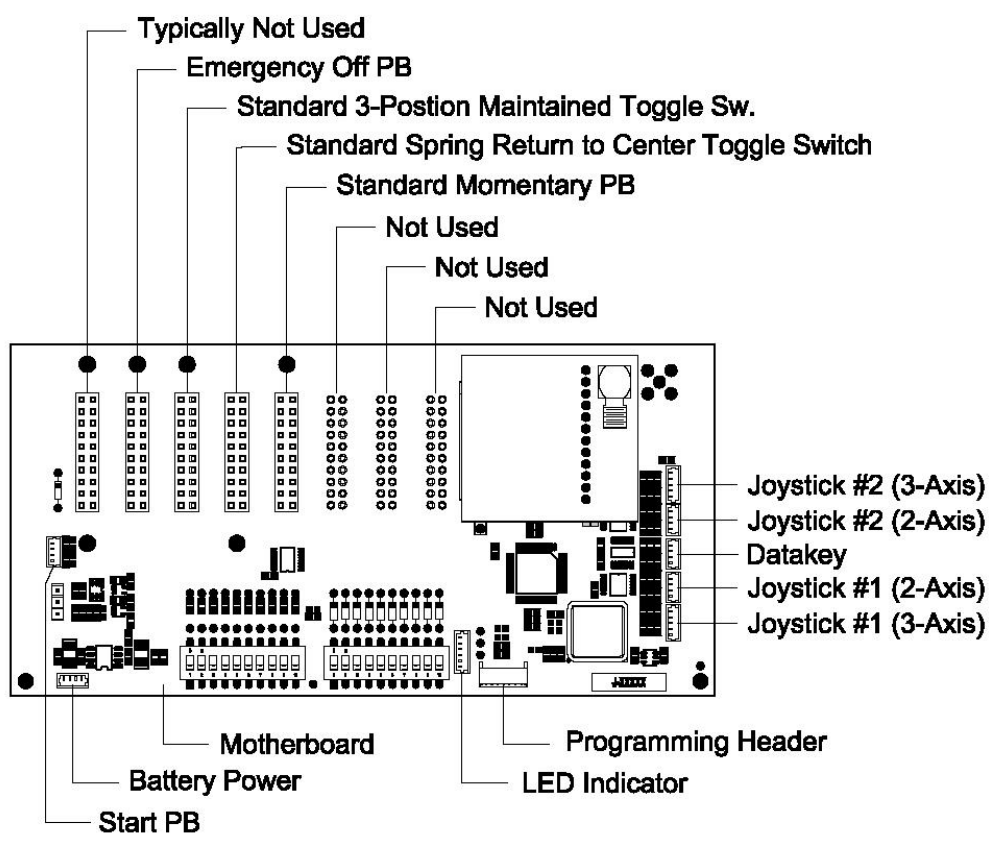
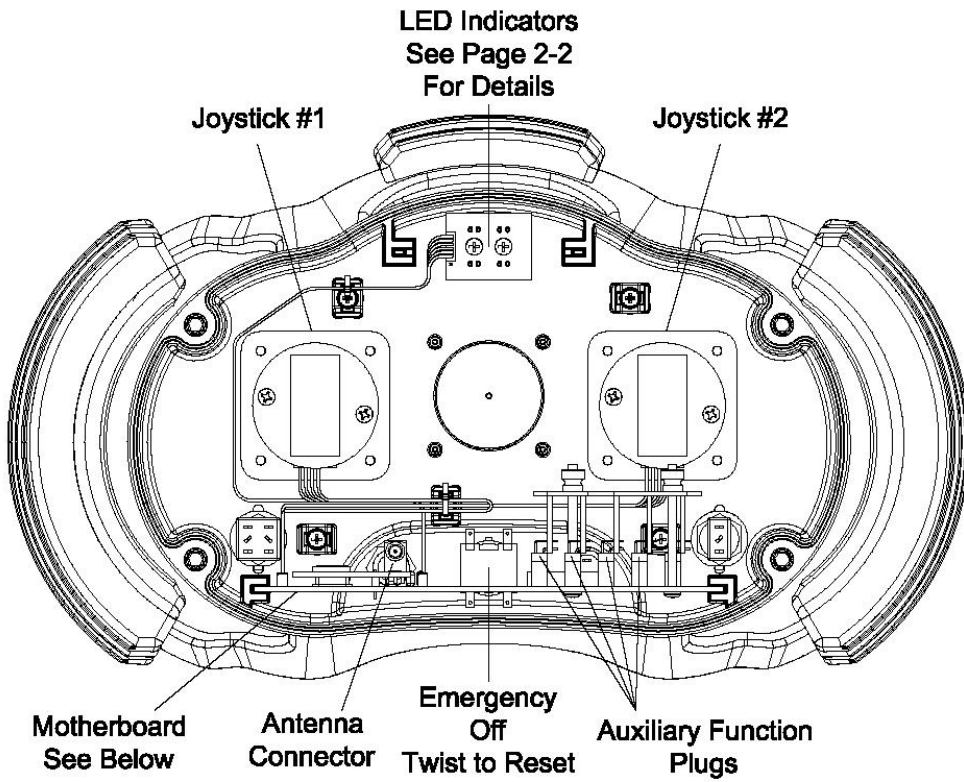

Fig. 5-1 Joystick Transmitter  
(Internal Components)

5.2.3 Receiving Equipment - The receiving equipment consists of a Receiver, a Controller, a Decoder and miscellaneous components (transformer, antenna, enclosure, etc.).

5.2.3.1 Receiver - The transmitter command signals transmitted to the Receiver are processed by the Receiver and are conducted to the Decoder via the Receiver Cable and the Controller board. The Decoder will return a command to the Receiver to lock onto a radio RF channel from which a valid address code has been received.

5.2.3.2 Decoder - The Decoder contains the DC power supplies and the logic processing circuits to convert the signals from the Receiver into output signals to drive the required relays. All of the relays on the Controller except the Master Relay are operated directly from the Controller.

5.2.3.3 Controller - The Controller contains the relays and terminal strips to provide isolation circuits to the Crane Controls. Each of the relays has an indicating light (LED and dropping resistor) parallel to its coil to provide an indication of the operation in progress.

Side Board(s) - The Side Board contains the Relays and terminal strips to provide isolation circuits to the Hoist 2 and Trolley 2\* Crane controls. Each of the relays has an indicating light (LED and dropping resistor) parallel to its coil to provide an indication of the operation in progress.

**WARNING:** The set of DIP switches next to the Decoder connection are used to set the Receiving equipment Address at the factory. DO NOT attempt any alteration!

\* Optional

The Controller board and Side Boards have printed traces of two widths - the wide traces are at crane control voltage (117 VAC) and most (but not all) are on the back of the board while the narrow traces (low voltage AC and DC) are on both sides of the boards.

CAUTION: Keep fingers off of the back of the board!

CAUTION: Keep fingers off of the fuse!

CAUTION: Use extreme care when probing the board with voltmeter probes, etc.!

MAINTENANCE CHECKS

CAUTION: MAKE CERTAIN THAT THE POWER SWITCH IS 'OFF' WHILE PLUGGING OR UNPLUGGING, CONNECTING OR DISCONNECTING ANY COMPONENT. Non-observance may result in damage and void the warranty.

CAUTION: When the Master Relay (and Main Contactor) is energized, any energized motion relay will cause crane motion.

Refer to Block Diagram, Fig. 3-2 and Schematic, Controller, to assist in tracing trouble.

5.2.3.4 System Functional Test -

CAUTION: REMOVE MASTER RELAY BEFORE PERFORMING THIS TEST TO AVOID INADVERTENT CRANE MOTION.

This test is performed with Transmitter in view of the Controller so that the LED indicators and relays may be observed. Have all modules in place, Transfer Switch in "Radio" and Power Switch "On" (Neon Indicator lit).

| <u>Action</u>   | <u>Anticipated Result</u>   |
|---|---|
| 1. Twist to release EMO Mushroom switch and                         |   |
| 2. Depress the Start PB   | momentarily until push button is released.<br>(Observe indicators).<br>Master relay indicator will light. |
| 3. Operate "Aux" switch* to "1" and "2" in turn.                    | "Aux" "1" and "2" relays will operate.  |
| 4. Operate motion switches forward (down) and reverse (up) in turn. | Each function relay is energized in turn. 2nd, 3rd, 4th & 5th speeds energize in either direction.        |

\* Optional



If any relay and its LED indicator fails to operate, replace the Decoder. (See "CAUTION", top of Page 5-6).

This test provides an opportunity to observe the relays operate mechanically and an opportunity to detect a defective relay. It may also be used as an aid in locating problems in the output circuits to the crane.

NOTE: If step 1 does not provide any of the indications noted and all voltage checks of para. 5.2.3.5 are correct, replace the Address relay. (See "CAUTION", top of Page 5-6).

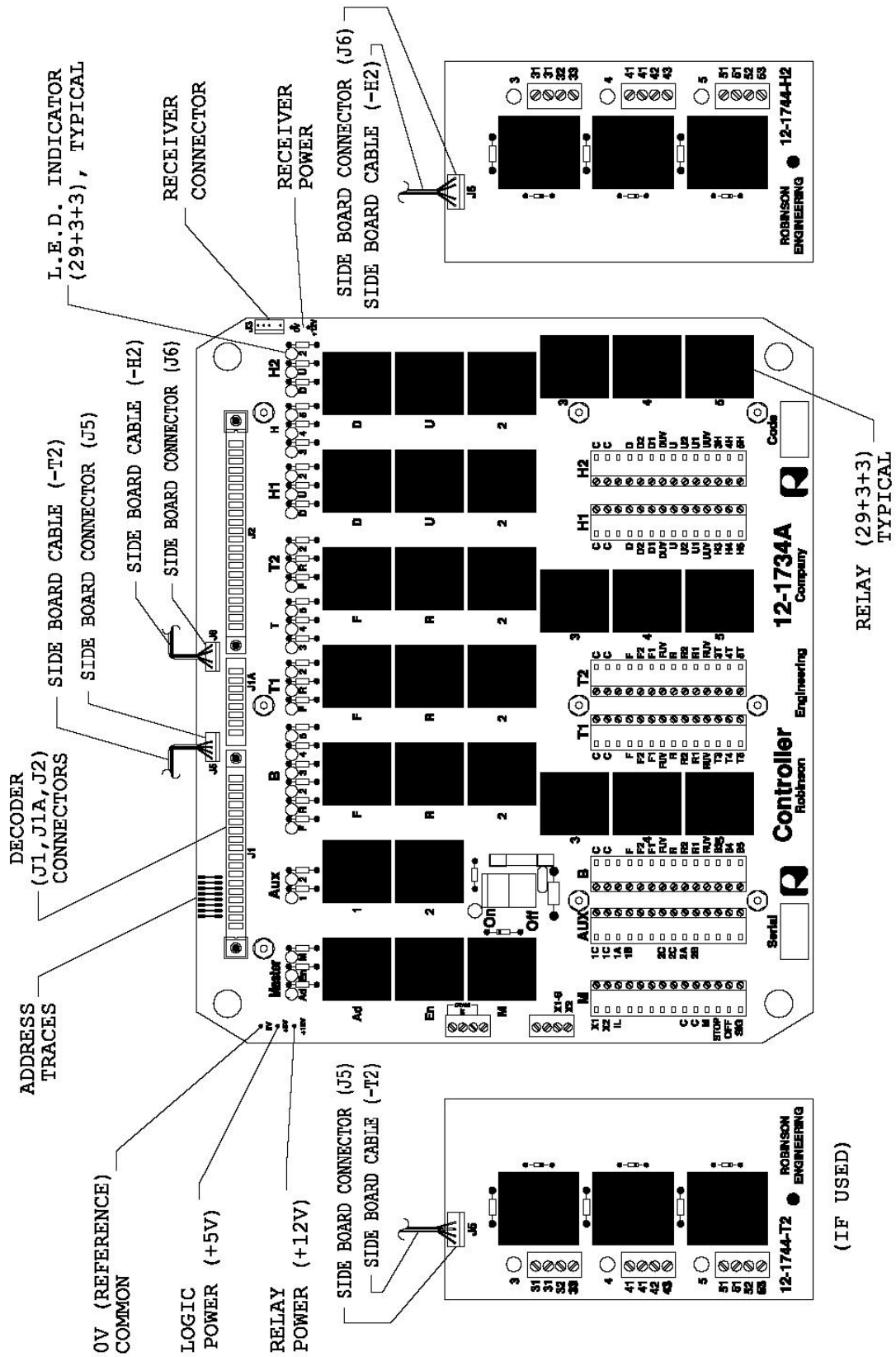

FIG. 5-2 (M)

5.2.3.5 Voltage Checks:

| <u>Test Points</u>                                | <u>Voltage</u>   | <u>Test for</u>                               |
|---|--|---|
| Terminals "X1", "X2"                              | 117 VAC  | <u>Input power</u>                            |
| Terminals "X1S", "X2"<br>(Neon indicator lighted) | 117 VAC  | <u>Power switch</u><br>"On", <u>Fuse OK</u> . |
| Terminals "24 VAC" (2)<br>and "CT"                | 24 VAC (between<br>designated<br>terminals), 12<br>VAC between "CT"<br>and each of the<br>above terminals. | <u>Transformer</u><br>Output.                 |

If any of the above checks fail to provide the noted voltage reading, the component involved should be repaired or replaced. (See "CAUTION", top of Page 5-6).

|  |   |                                  |
|--|---|----------------------------------|
| Controller board OV<br>and +5V (left and above<br>"Ad" relay)*   | 5 " .2 VDC  | Decoder 5 VDC<br>logic power     |
| Controller board OV<br>and +12V (left and above<br>"Ad" relay).* | 15 to 18 VDC<br>no load.*<br>9.5 to 11.0<br>VDC under max.<br>relay load. | Decoder 12 VDC<br>relay power    |
| Controller board OV and<br>+12 VDC (below receiver<br>connector) | 15 to 18 VDC  | Decoder 12 VDC<br>Receiver power |

- \*Note:
- 1) Transformer may need to be loosened from mounting.
  - 2) The type of meter used will vary the "no load" readings considerably.

If any of the above checks fail to provide the noted voltage readings, the Decoder should be replaced. (See "CAUTION", top of Page 5-6).

5.2.3.6 Receiver - use the Transmitter qualitative test, para. 5.2.2.2 to check the Receiver. If receiving range appears to be reduced, check antenna for defects and proper connections. Make certain that the "Squelch" is set at wide open, its max clockwise position, for maximum range.

Note: The cable connecting the Receiver to the Controller should not be ignored. A continuity test may be appropriate. (See "CAUTION", top of Page 5-6).

5.2.3.7 Decoder - The only check for a suspected defective Decoder is substitution of a spare module.

5.2.3.8 Controller - Refer to Schematic, Controller, for assistance in circuit tracing.

CAUTION: When the Master (and Main Contactor) is energized, any energized motion relay will cause crane motion.

With Transmitter "Off", all relays (and LEDs) should be de-energized.

Main Circuit - This circuit is designed to operate in the following sequence:

1. Transmitter "Off", all relays de-energized.
2. Transmitter "On", Address relay energized. Enable Pushbutton depressed, Enable Relay energized.
3. Address and Enable relays energize Master Relay (M) if all Transmitter function controls are "Off". Address relay must be energized before any other function relay may be energized.
4. De-energizing the Address Relay by turning the Transmitter "Off" de-energizes the Main Contactor, Enable and Master relays.

The Master Relay is controlled by relay contact circuits only. An examination of the Schematic will reveal a series of normally closed circuits. If any of these relays are energized, the circuit will open, not allowing the master relay to energize.

This is also true of any of these relays are missing or have a defective contact.

Also note, if the Address and Enable relays are not energized, the Master Relay cannot energize.

Safety Circuit - This circuit is a comparison circuit between the Address relay and the Enable relay condition providing for a system shut down in the event of a mis-match of more than a fraction of a second duration.

5.3 REPLACEABLE PARTS

When purchasing parts from the factory, please provide the Serial Number of your equipment (See nameplate on Transmitter or Receiving Equipment).

| Quantity/<br><u>Kit</u>         | Quantity      | Recommended        |               |
|---------------------------------|---------------|--------------------|---------------|
|                                 | <u>System</u> | <u>Spare Parts</u> | <u>Spares</u> |
| 5.3.1 Transmitting Equipment:   |               |                    | 1             |
| Transmitter, Crane Boss II      | 1             | 1                  |               |
| Shoulder Harness                | 1             |                    |               |
| Aux Switch Assembly*            | 1-2           |                    |               |
| with Boot                       |               |                    |               |
| Boot only                       |               |                    |               |
| 5.3.2 Receiving Equipment:      | 1             | 1                  | 1             |
| Control Receiver                | 1             |                    |               |
| Receiver Cable                  | 1             |                    |               |
| Antenna Cable                   | 1             |                    |               |
| Antenna                         | 1             |                    |               |
| Decoder                         | 1             |                    |               |
| Relay, <u>12 VDC</u> , Mini 10A | 32-35         |                    |               |
| Retainer                        | 32-35         |                    |               |
| Fuse, 8AG-2A                    | 1             |                    |               |
| (not instrument rating)         |               |                    |               |
| Transformer, 117/24V (CT)       | 1             |                    |               |
| (50 VA)                         |               |                    |               |
| Controller (Relay PC            | 1             |                    |               |
| Assembly) w/Relays*             |               |                    |               |
| Side Board w/Relays*            | 1-2           |                    |               |

\* Need Transmitter Serial Number