

TABLE OF CONTENTS

	PAGE
SECTION 1 GENERAL INFORMATION	
1.1 SCOPE	1-1
1.2 SYSTEM DESCRIPTION	1-1
1.3 WARRANTY	1-4
SECTION 2 OPERATION	
2.1 RECEIVING EQUIPMENT	2-1
2.2 TRANSMITTER	2-1
2.3 OPERATING PROCEDURE	2-1
2.4 MISCELLANEOUS OPERATING INFORMATION	2-2
SECTION 3 PRINCIPLE OF OPERATION	
3.1 RADIO CONTROL SYSTEM	3-1
3.2 TRANSMITTER	3-2
3.3 RECEIVING EQUIPMENT	3-5
SECTION 4 INSTALLATION INFORMATION	
4.1 SCOPE	4-1
4.2 MOUNTING	4-1
4.3 TRANSFER SWITCH	4-2
4.4 OUTPUT CIRCUITRY	4-5
4.5 INTERFACE LOGIC PANELS	4-6
4.6 START-UP PROCEDURE	4-7
SECTION 5 MAINTENANCE	
5.1 PREVENTIVE MAINTENANCE	5-1
5.2 CORRECTIVE MAINTENANCE	5-1
5.3 REPLACEABLE PARTS	5-11
APPENDICES	
I INDEX	I-1
II OPTIONS	II-1

TABLE OF FIGURES

FIGURE	TITLE	PAGE
3-1	BLOCK DIAGRAM, TRANSMITTER	3-3
3-2	BLOCK DIAGRAM, RECEIVING EQUIPMENT	3-4
4-1	TYPICAL TRANSFER SWITCH & MAIN LINE	
4-2	CONTACTOR CIRCUIT	4-3
4-2	OUTPUT CIRCUIT FUNCTIONAL DIAGRAMS	4-4
5-1H	TRANSMITTER COMPONENTS	5-3
5-2	CONTROLLER	5-7 & 5-8

DRAWING LIST

NUMBER	TITLE
12-1606	OUTPUT CIRCUITS, CRANE BOSS 200
12-1607	SCHEMATIC, CONTROLLER, CRANE BOSS 200
12-1608	OUTLINE, CRANE RADIO CONTROL, CRANE BOSS 200

SECTION 1

GENERAL INFORMATION

1.1 SCOPE

This manual contains information necessary to install, operate and maintain Crane Boss 200 Radio Remote Control Systems, which use a Hand-Held Transmitter. Receiving equipment information is generally applicable to all Crane Boss 200 systems manufactured by Robinson Engineering Company.

1.2 SYSTEM DESCRIPTION

1.2.1 General – The “200” system is equipped with controls and accessories required for reliable electrical operation of a crane or other machinery from a portable wireless control transmitter.

1.2.2 Control functions provided:

On/Off/Emergency Stop/Indicating Light

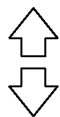

‘H1’ - Down / Up, Lo & Hi speed



‘T1’ - Forward / Reverse, Lo & Hi speed



‘B’ - Forward / Reverse, Lo & Hi speed

‘Aux 1’ - On/Off (Maintained Toggle)

‘Aux 2’ - On/Off (Maintained Toggle)

‘Aux A’ - (Momentary Pushbutton)

‘Aux B’ - (Momentary Pushbutton)

1.2.3 Characteristic features are:

1. Each system consists of a portable control transmitter, which operates, in conjunction with receiving equipment installed on the machinery structure and electrically connected to the magnetic controllers.
2. “Fail-safe” circuits are used throughout the system.
3. The command link is capable of handling all motions simultaneously.
4. The system uses digital pulse code frequency modulation. It was developed specifically for industrial control.
5. The system utilizes fully solid-state electronic circuits, with heavy-duty relay contact output circuits.
6. Maintenance requirements are greatly reduced by modular design and use of digital switching circuits. No special test equipment is required.
7. Radio control of several units in the same plant without interference is entirely practical. Each transmitter transmits a unique address code, which prevents response by other than the intended unit. In addition, the operating frequencies of different units are staggered within the frequency band to prevent interference. Proper selection of address codes and operating frequencies with respect to physical separation provides control of multiple installations with no practical limitation on the number at one location.

- 1.2.4 Transmitter – The transmitter is a portable unit, which is carried by the operator. Switches on the transmitter control all functions as labeled.

The portable transmitter weight is just over 1 pound. The transmitter includes an external antenna and has a battery assembly attached. The battery assembly uses a 3-volt expendable battery. The Lithium battery Type 123A supplied with the transmitter will provide approximately 80 hours of continuous transmitter operation.

- 1.2.5 Receiving Equipment – The receiving equipment cabinet is mounted on the machinery and contains the radio-receiving unit, decoding equipment and relays to convert the radio signal from the transmitter to signals suitable for operation of magnetic controls' contactors.

1.3 GUARANTEE

Manufacturer Warrants the delivered remote control system to be free of defective material and workmanship and agrees to remedy any such defect within one year of first party purchase at no charge to the purchaser upon return of defective parts to factory. Defects caused by improper installation, maintenance, misuse, tampering, neglect, accident, or use in violation of manufacturer's written instructions shall not be covered by this warranty. Manufacturer guarantees that remote control system will perform as outlined in this manual.

Transferring of this warranty is acceptable and recommended. Please notify this factory of any and all transfers.

SECTION 2

OPERATION

2.1 RECEIVING EQUIPMENT

Normal operating procedure is to leave receiving equipment energized at all times. (Power switch "On", neon indicator lighted). The unit can then be readily placed in operation by means of the portable control transmitter.

2.2 TRANSMITTER

The transmitter should be stored in a secure location when not being used.

2.3 OPERATING PROCEDURE

To place the unit in operation, proceed as follows:

1. Operator should position himself so as to have a clear view of the motions and actions.
2. Turn the Transmitter ON: With all operating controls in "Open" position, push "Start" Pushbutton. "OK" indicating light will flash on transmitter. Master relay and main line contactor are energized.
3. Move the Bridge, Trolley, and/or Hoist: Machinery can now be moved by operating desired control operators. All motion controls are spring loaded to "Open". Pressing the desired directional pushbutton actuates the low Speed.
4. "2nd" or "H1" speed: With the desired directional pushbutton depressed, press the pushbutton marked "+" next to it.
5. In the event of an emergency situation, press the "Stop" button.
6. Upon completion of use, turn transmitter "Off" by pressing the "Stop" pushbutton and replace transmitter in designated storage location with "Power" OFF.

NOTE: The transmitter will automatically "power down" (turn off) if no motions are activated over a time period.

2.4 MISCELLANEOUS OPERATING INFORMATION

Abnormal electrical conditions during operation will de-energize control circuits, stopping motion. This can be caused by any one of a number of abnormal conditions. Among these are:

1. Weak or improper radio signal.
2. Interruption of power to receiving equipment.
3. Radio interference.
4. Malfunction of radio equipment.
5. Malfunction of machine electrical equipment.

If the abnormal condition is temporary, control can be resumed by repeating steps 2. through 4. of paragraph 2.3 above. The exact sequence of operation must be followed to accomplish operation of safety circuits in the receiving equipment.

SECTION 3

PRINCIPLE OF OPERATION

3.1 RADIO CONTROL SYSTEM

The Crane Boss system is simple to operate. The transmitter unit incorporates an easily operated control pushbutton for each crane motion. Pressing the pushbutton moves the crane in the requested direction. A “Start” pushbutton energizes the master circuits and, hence, the main line contactor. All function control pushbuttons return to an “open” condition (dead-man action) when released, and motion stops. Fail-safe features are used throughout the circuitry. All crane motion stops in case of malfunction.

The transmitter(s) in your Crane Boss system transmit unique digital crane address codes to each crane. This prevents any mix-up in crane response. Only one crane responds to one special code when transmitted. Hundreds of these address codes are available. For added protection, operating frequencies of each transmitter in the same area can be staggered within the frequency band to prevent interference. The proper selection of digital address codes and operating frequencies relative to physical separation permits control of an unlimited number of cranes in the same plant, area or city.

3.2 TRANSMITTER

The transmitter is a battery operated frequency modulation radio transmitter. Incorporated with the transmitter is an antenna and disposal battery. Transmitter carrier frequency is crystal controlled. When the various switches are actuated, coded control signals are sent to the receiving equipment via the antenna. A block diagram of the transmitter is shown by Fig. 3-1.

The RF Assembly generates the radio frequency signal radiated by the antenna, and is frequency modulated by a pulse code modulation signal. This modulation signal is generated by the Coder Assembly and consists of a series of synchronizing pulses that are determined by the position of the various function controls, which are actuated by the operator.

Coder Assembly used in all transmitters is identical in function and is interchangeable. Variation in code format between systems is accomplished by means of factory connections on the Junction Board, by the Address Plug, and by writing to the various control devices. All RF Boards for the same frequency bands are identical and interchangeable except for the frequency.

In multiple system installations a given transmitter may be converted from control of one crane to another by changing the Address Plug installed in the transmitter**. The Scanning Receivers used in multiple systems installations are normally supplied with capability of receiving all transmitting frequencies used at that installation.

** See 5.2.2.3

EXTERNAL COMPONENTS

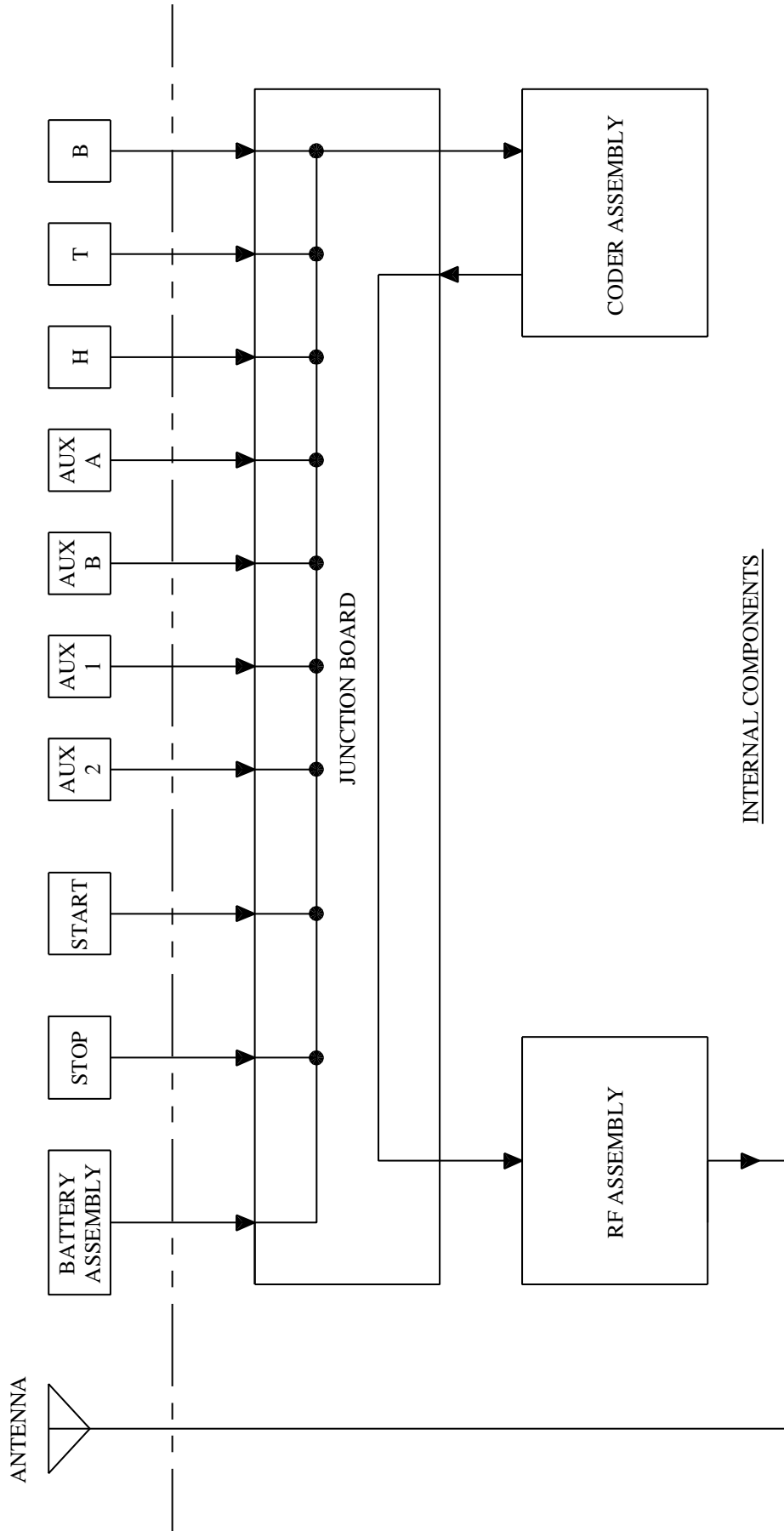

FIG. 3-1: BLOCK DIAGRAM, TRANSMITTER

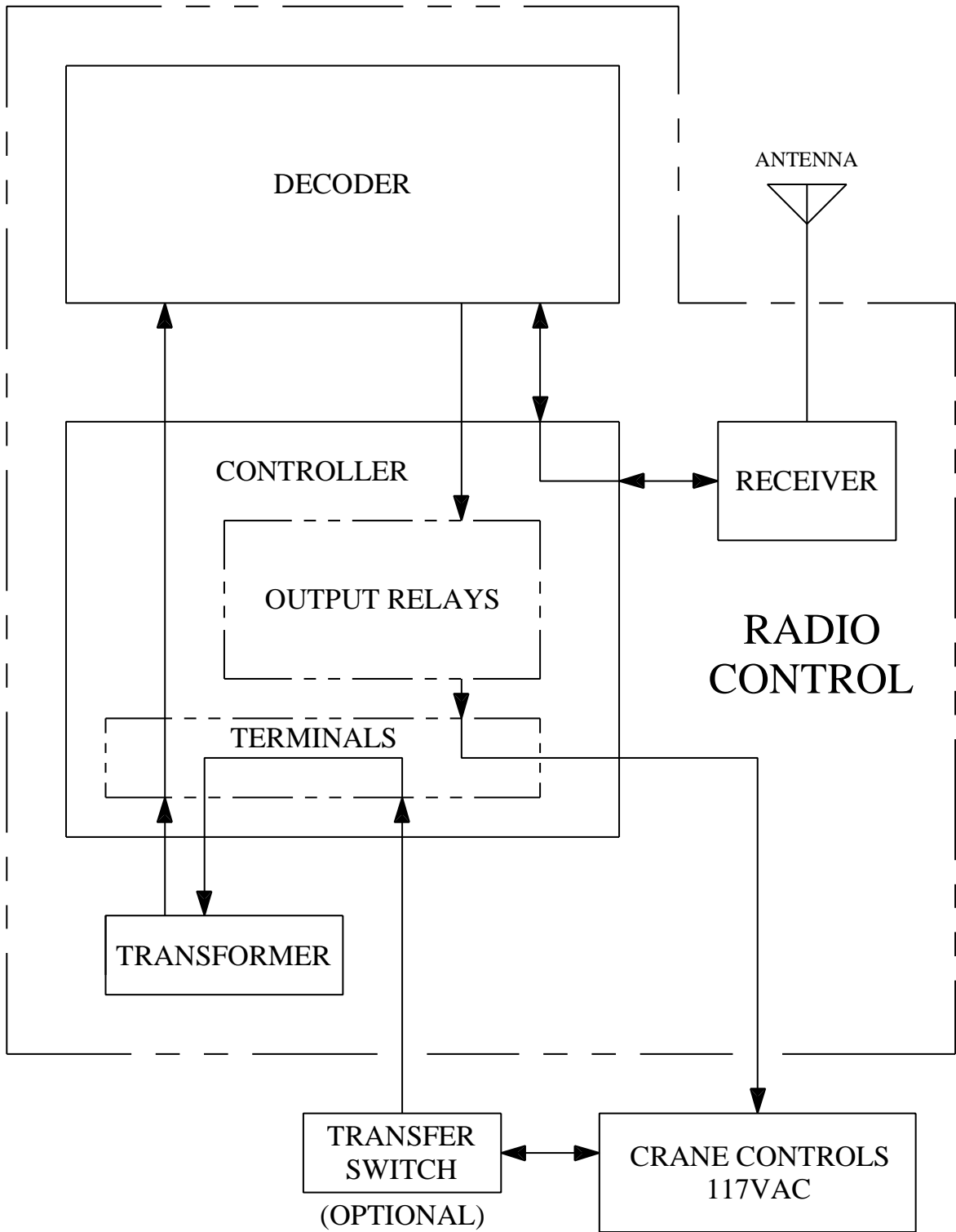

FIG. 3-2: BLOCK DIAGRAM, RECEIVING EQUIPMENT

3.3 RECEIVING EQUIPMENT

Figure 3-2 shows a block diagram. The radio signal from the transmitter is received by the antenna, which is connected to the Receiver by coaxial cable. Receiver data output is fed to the Decoder, where it is decoded and signals suitable for operation of the output relays are generated. The output relays provide heavy-duty control circuits to the basic machine electrical controllers.

3.3.1 Antenna - The Antenna is pre-tuned for the frequency band used.

3.3.2 Receiver - The Receiver amplifies and detects the frequency modulated pulse code signal and includes filtering and shaping circuits to process the signal. Data output consists of rectangular pulses of 5 volts amplitude which are a replica of the transmitter coder output.

The Receiver is a synthesized frequency controlled scanning type receiver which continuously scans all selected channels until a signal is received which contains the proper address code. When proper address code is received, scanning stops and, the receiver remains "locked-on" that channel for as long as the code remains.

Channels can be turned "Off" or "locked-out" when unused or turned "On" when other equipment is added.

A "VOLUME" control is provided to permit audio monitoring, via internal loudspeaker, of the received signal for test and maintenance purposes. This control has no effect on the control function of the system and should be left in the full (CCW) off position during normal operation.

- 3.3.3 Decoder - The receiver data output is connected to the Decoder through the Controller, where it is processed into form suitable for operation of the Relays. The Decoder also performs certain synchronization, safety interlock, and digital filtering and noise rejection functions. All DC voltages originate in the Decoder.
- 3.3.4 Address Code - The address is a two digit hexi-decimal number that is set at the factory. The number for each system is shown in the “Code” number block on the Controller.
- 3.3.5 Output Relays - Relay contact logic circuits provide additional safety sequencing and interlocking functions. Output circuits are connected to terminal blocks for connection to magnetic controllers. Output relay circuits are rated for operation of up to NEMA size 3 contactors at a maximum coil voltage of 125 volts A.C.

SECTION 4

INSTALLATION INFORMATION

4.1 SCOPE

This section is intended as aid to preparing for mounting and interconnection of Crane Boss to machinery, crane or monorail. The examples and suggestions made as to the mounting and interconnection are based upon typical uses and past experience; depending upon application, these may or may not be applicable or appropriate.

The installer is cautioned to assure that requirements of applicable Codes and Ordinances are complied with.

4.2 MOUNTING - RECEIVING EQUIPMENT

- 4.2.1 Refer to Outline Drawing for mounting dimensions and clearances required.
- 4.2.2 Rigidly mount, as for any control panel, the Receiving Cabinet to the structure of the equipment to be remotely controlled. Allow access for conduit entry as noted on the Outline Drawing.
- 4.2.3 Mounting of the Indicating Light (if used) is accomplished by normal electrical wiring procedures. Be sure of visibility from operating area. Also, that it be conveniently accessible for service (changing bulb, etc.). Terminals IL and X2 are used for the Indicating Light.

4.2.4 The antenna is installed by plugging into the jack on the bottom of the Crane Radio Control cabinet.

4.2.4.1 If an antenna location other than the bottom of the cabinet is required, an optional kit for remote installation is available*

4.2.4.2 Proper mounting and location of antenna is imperative for signal to reach decoding and output circuits. (See Notes on Outline Drawing.)

4.2.4.3 Mounting of the Receiving enclosure should allow for the Antenna to be:

1. Clear of large metal objects, bring greater than one foot away from bridge girders, hoist mechanism, etc;
2. In view from the entire operating area, in all directions;
3. And not in close proximity to crane electrification, like runway conductors, bridge cross conductors, festooning, conduit or wire way.

If any of these conditions cannot be met, a Remote Antenna Kit should be used. *

4.2.5 Wherever the “other” means of control (console, pendant, etc.) is located (trolley, bridge) is probably the simplest wiring location for the radio control cabinet. The only distinct difference between pushbutton and radio control is that 117 VAC must be available for radio power supply. Pushbuttons will have as a common the “hot” lead. The other leg of the transformer (X2) must often be added by conductor bar, festooning, or by other means.

4.3 TRANSFER SWITCH

4.3.1 Mutually exclusive transferring of control modes is often used: “Pushbutton-Radio”, “Cab-Radio”, “Pendant-Radio”, “Console-Radio”, etc. The mutual exclusivity is most simply obtained by appropriately defeating the other mode’s power feed, as well as, opening any normally closed circuits. See Fig. 4-1.

* See “Options” Appendix.

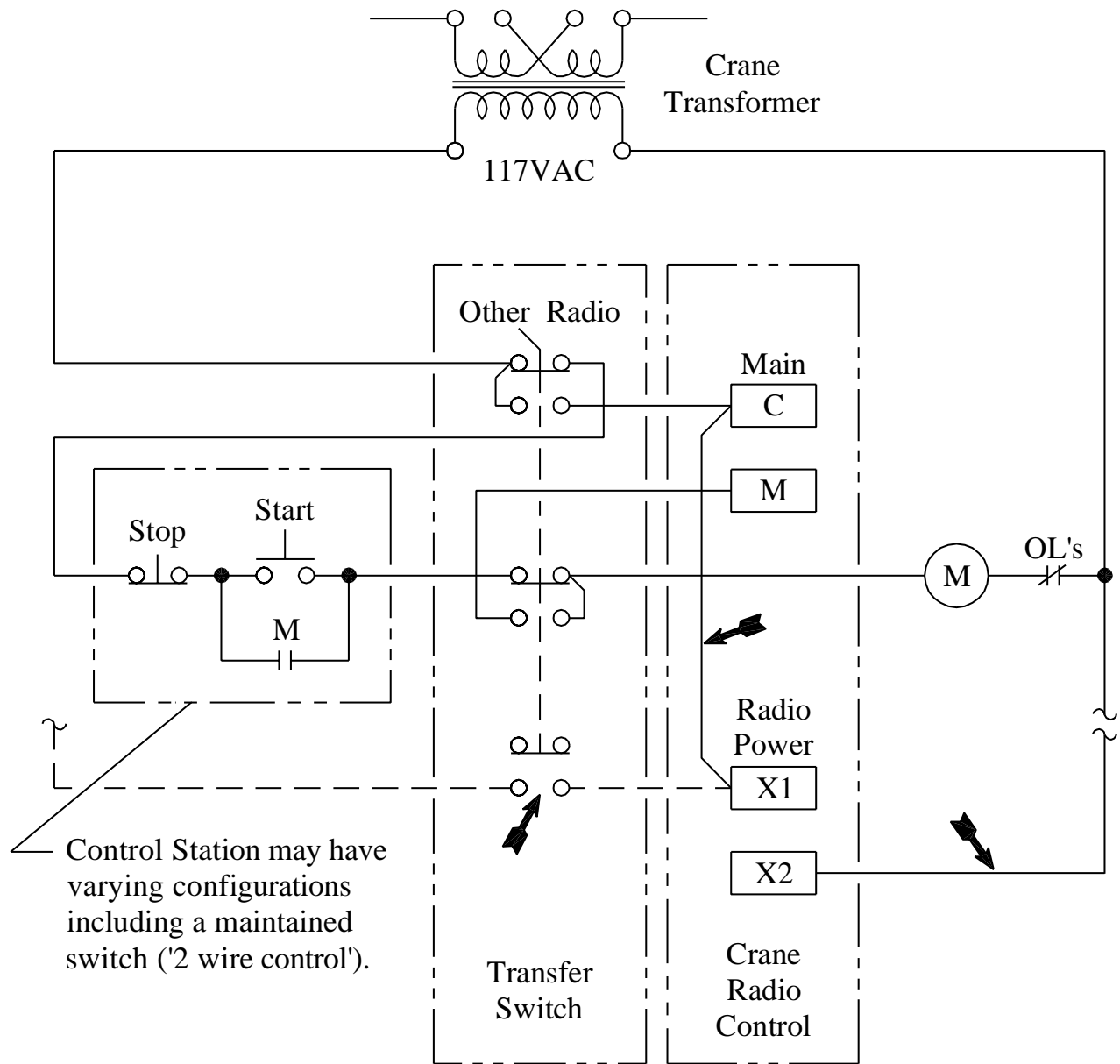

➡ If Radio Power is to be separate from Main Power, omit jumper from C (Main) to X1 and add Transfer Switch contact with dashed line connection as shown. X2 must be connected to the same power source as X1.

NOTE: This diagram is an example only. Equipment control circuits may vary greatly. Control connections should be carefully considered to provide proper operation and avoid feedback circuits.

FIG. 4-1:
TYPICAL TRANSFER SWITCH & MAIN LINE CONTACTOR CIRCUIT

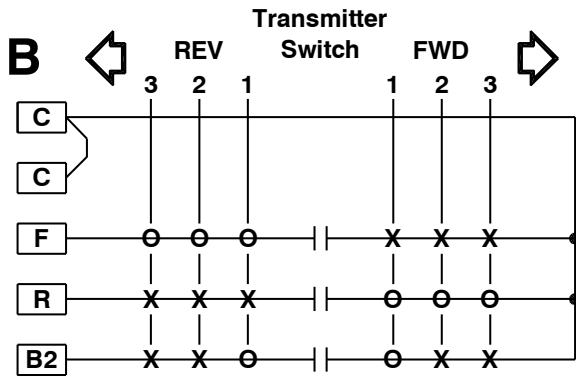
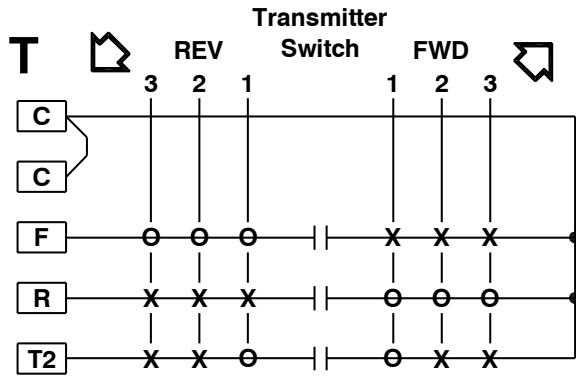
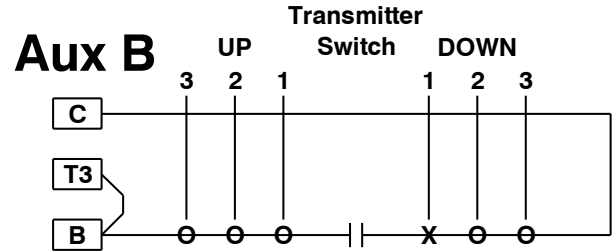
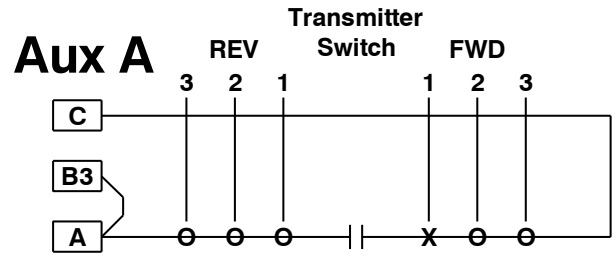
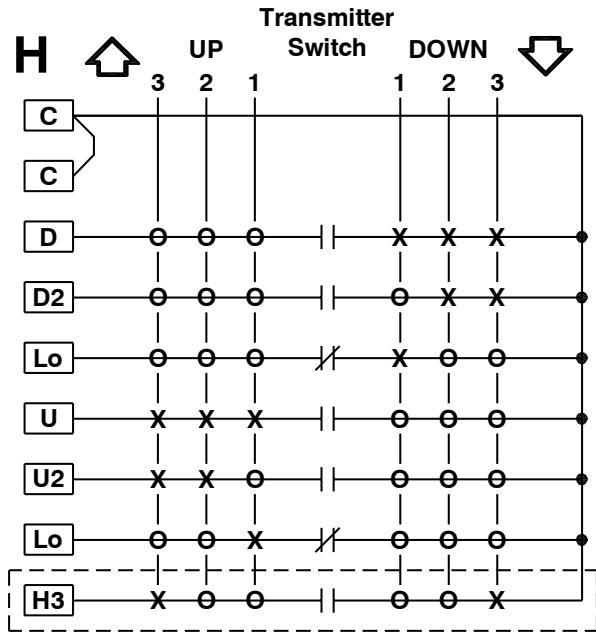

X: Indicates Closed Circuit

O: Indicates Open Circuit

[]: Indicates Optional Circuit

Crane Boss

BATT.
 ○ Low
 ○ OK

STOP
 START
 1
 2
 A
 B

3 Volts Type 123A +

Robinson Engineering Co.
 Garland, Texas
CONTROL TRANSMITTER
 FCC TX DATA: TYPE 400-72
 SERIAL NO.

FIG. 4-2(G): OUTPUT CIRCUIT FUNCTIONAL DIAGRAMS

INTERFACE LOGIC PANELS

4.5.1 Required uses:

4.5.1.1 Contactor control voltage exceeds 120 VAC (cab masters are often full voltage) - see 4.5.2.

4.5.1.2 Contactors larger than size NEMA 4, or multiple contactor coils are simultaneously operated.

4.5.1.3 Contactors with DC coils are used.

4.5.2 Upgrading Contact Rating

4.5.2.1 When voltage or current rating of output contacts is insufficient to operate a contactor directly, an interposing relay must be used.

4.5.2.2 The coil of the interposing relay used should be operable within the output contact ratings:

120 VAC, maximum size NEMA 4 contactor.

4.5.3 Logic Expanding

4.5.3.1 When more than one contact closure per output is required or additional logic through combinations requires more output contacts than available at the terminal strip, additional contacts must be made available through the use of interposing relays.

4.5.3.2 The addition of a logic panel can also simplify pendant, pushbutton, or cab master wiring. Assure isolation of all operating modes by the application of the Transfer Switch. Equipment control circuits may vary greatly. Control connections should be carefully considered to provide proper operation and avoid feedback circuits.

4.6 START-UP PROCEDURE

4.6.1 Before Power-up Check List:

- 1. Cabinet mounted per Outline Drawing and Manual paragraph 4.2.
- 2. All conduit entry thru bottom of cabinet, away from Antenna.
- 3. Receiving Antenna must be visible from operating area, in all directions and over entire range of operation. *
- 4. Internal components and connections are tight and secure.
- 5. Channel(s) for transmitter(s) to operate unit are selected on the Scanning Control Receiver. See tag(s) on transmitter(s) for frequency & channel.
- 6. Transfer Switch, if used is in "Radio"

4.6.2 Receiving Power-up Check List: (Transmitter off)

- 1 With "On/Off" Rocker Switch on Controller in "Off" position, turn on supply-power to radio (and control-voltages of crane). Measure 100 to 140 VAC between radio terminals 'X1' & 'X2'.
- 2 Smoke Test: Press Rocker Switch to "On" position. Neon Indicator, next to Rocker Switch, lights and Control Receiver scans thru all selected channels continuously.
- 3 Airwave Check: With squelch full clockwise, turn up volume on Control Receiver. Listen for any signals present on selected operating channels. Pure "hissing" is a welcome sound! Anything else indicates possible competition on that frequency.

4.6.3 Operational Check List:

- 1. Perform system Functional Test (5.2.3.4) on Manual page 5-5 using Operating Procedure (2.3 on Manual Page 2-1), ALL functions, even if not used on this application.

- 2. Range Test:

Employing proper safety precautions, operate from the extreme locations in the area.

- 3. Show & Tell everyone who will listen!

- 4. Leave the Operation & Maintenance Manual on-site, since it will be what is needed when it is need and where it is needed!

4.6.4 Problems

See Section 5 in the Operation & Maintenance Manual. If perplexed, call the Robinson Engineering factory from on-site. Have serial number of unit and Manual ready!

SECTION 5

MAINTENANCE

The system is of modular design, with plug-in type electronic sub-assemblies and readily replaceable electrical components. Trouble can be corrected by locating and replacing the defective part, using the substitution method. It is suggested that spare parts be obtained for replacement purposes. Field repair of electronic sub-assemblies is not recommended. Improper techniques can result in damage to components and voiding of warranty. The factory will provide prompt test and repair or replacement of returned defective or questionable parts, including the complete transmitter, at nominal costs; or at no cost under warranty. Federal Communications Commission Rules and Regulations require that tuning adjustments on the radio frequency (RF) portion of the transmitter be made only by a properly licensed person.

5.1 PREVENTIVE MAINTENANCE

No preventive maintenance is required except for periodic inspection for security of hardware, harnessed internal wiring and to check for intrusion of dirt or foreign matter. Relay contacts may be checked for excessive arcing by cycling through all motions. Replace parts as necessary.

5.2 CORRECTIVE MAINTENANCE

5.2.1 General - In case of suspected Radio Remote Control System trouble, activate the back-up controls and check for normal machine operation. If back-up system operation is not normal, locate and correct trouble in basic equipment before proceeding to radio equipment.

5.2.2 Transmitter – (See Block Diagram, Transmitter, Fig. 3-1, and Transmitter Components, Fig. 5-1H).

5.2.2.1 Replaceable Battery – Battery voltage may be measured at the battery terminals. A green indicating light “OK” will flash if battery voltage is adequate. If the battery is low, the red indicating light “LOW” will flash, and the battery should be replaced.

5.2.2.2 Transmitter Test – A simple qualitative check of transmitter operation may be made by monitoring the receiver. A normal signal will exhibit a characteristic 25-Hertz “motorboat” sound in the Receiver speaker due to the 25 Hz. Pulse modulation. Failure to quiet receiver noise indicates no transmitter output. Receiver quieting, but without presence of modulation, indicates RF output, but defective transmitter coder.

CAUTION: When the Master Relay (and Main Contactor) is energized, any energized motion relay will cause crane motion.

5.2.2.3 Multiple System Applications – A transmitter may be converted from operation of one unit to another by changing the Address Plug installed in the transmitter. The unit to be controlled must have the proper receiver frequency channel activated. Each transmitter frequency is marked on the frequency control crystal.

Access to the interior of the transmitter is made by removing the two Phillips head screws retaining the stainless steel box and removing the face panel assembly. Internal arrangement of parts is shown by Figure 5-1H. Address Plugs may be accessed by unplugging from bottom of transmitter electronics assembly.

The Coder and RF Assemblies are connected to the Junction Board electrically and mechanically by two connectors oriented perpendicular to the boards.

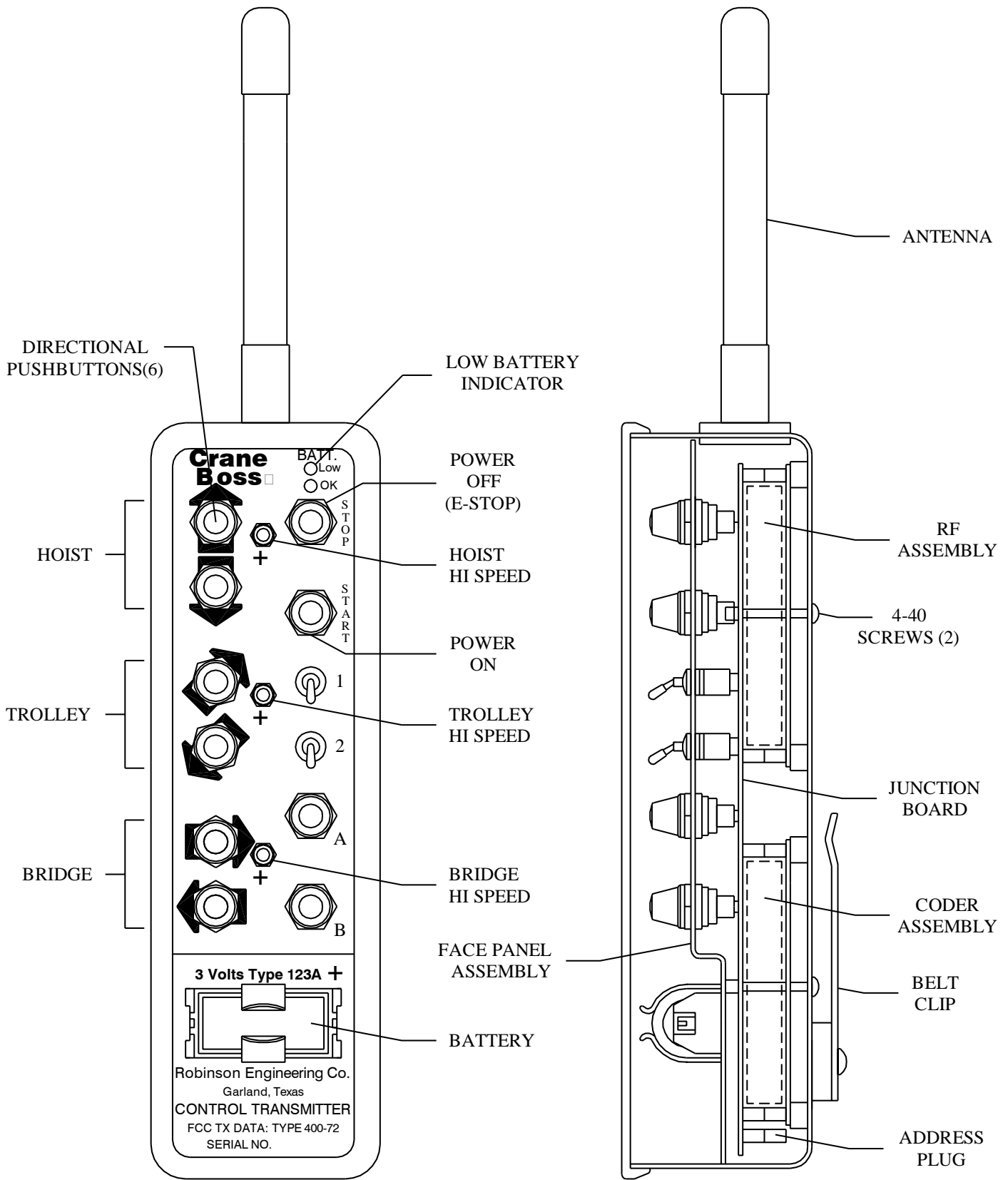

FIG. 5-1H HAND HELD, TRANSMITTER

5.2.3 Receiving Equipment – The receiving equipment consists of a Receiver, a Controller, a Decoder and miscellaneous components (transformer, antenna, enclosure, etc.).

5.2.3.1 Receiver – The transmitter command signals transmitted to the Receiver are processed by the Receiver and are conducted to the Decoder via the Receiver Cable and the Controller board. The Decoder will return a command to the Receiver to lock onto a radio RF channel from which a valid address code has been received.

5.2.3.2 Decoder – The Decoder contains the DC power supplies and the logic processing circuits to convert the signals from the Receiver into output signals to drive the required relays. All of the relays on the Controller except the Master Relay are operated directly from the Controller.

5.2.3.3 Controller – The Controller contains the relays and terminal strips to provide isolation circuits to the Crane Controls. Each of the relays has an indicating light (LED and dropping resistor parallel to its coil to provide an indication of the operation in progress.

WARNING: The set of parallel traces above the LH Decoder connection are used to Set the Receiving equipment Address at the factory. DO NOT attempt Any alteration!

CAUTION: Keep fingers off of the board!

CAUTION: Keep fingers off of the fuse!

CAUTION: Use extreme care when probing the board with voltmeter probes, etc.!

MAINTENANCE CHECKS

CAUTION: MAKE CERTAIN THAT THE POWER SWITCH IS 'OFF' WHILE PLUGGING OR UNPLUGGING , CONNECTING OR DISCONNECTING ANY COMPONENT. Non-observance may result in damage and void the warranty.

CAUTION: When the Master Relay (and Main Contactor) is energized, any energized motion relay will cause crane motion.

Refer to Block Diagram, Fig. 3-2 and Schematic Controller, to assist in tracing trouble.

5.2.3.4 System Functional Test -

CAUTION: REMOVE MASTER WIRE(S) BEFORE PERFORMING THIS TEST TO AVOID INADVERTENT CRANE MOTION.

This test is performed with Transmitter in view of the Controller so that the LED indicators and relays may be observed. Have all modules in place, Transfer Switch in "Radio" and Power Switch "On" (Neon Indicator lit).

<u>Action</u>	<u>Anticipated Result</u>
1. Turn Transmitter "ON" ("Start" Pushbutton)	Address and Enable relays will operate (observe indicators). Master relay indicator will light. See Note, page 5-6.
2A. Operate "Aux toggle Switches "1" and "2".	"Aux" "1" and "2" relays will operate.
2B. Operate Aux pushbuttons "A" & "B".	"A" will operate A and "B" will operate B.
3. Operate motion switches.	Each function relay is energized.
4 Operate "+" (second speed) of respective motion switch.	"B2", "T2" & "H2" relays Energized at the <u>addition</u> of the "+" pushbutton in <u>conjunction</u> with the chosen direction.

If any relay and its LED indicator fails to operate, replace the Decoder. (See “CAUTION”, above).

Motion Switches are electrically interlocked, causing “shutdown” of respective motion when opposite direction is energized at the same time.

This test provides an opportunity to observe the relays operate mechanically and an opportunity to detect a defective relay. It may also be used as an aid in locating problems in the output circuits to the crane.

NOTE: If step 1 does not provide any of the indications noted and all voltage checks of paragraph 5.2.3.5 are correct, replace the Controller. (See Safety Circuit, page 5-10). (See “CAUTION” above).

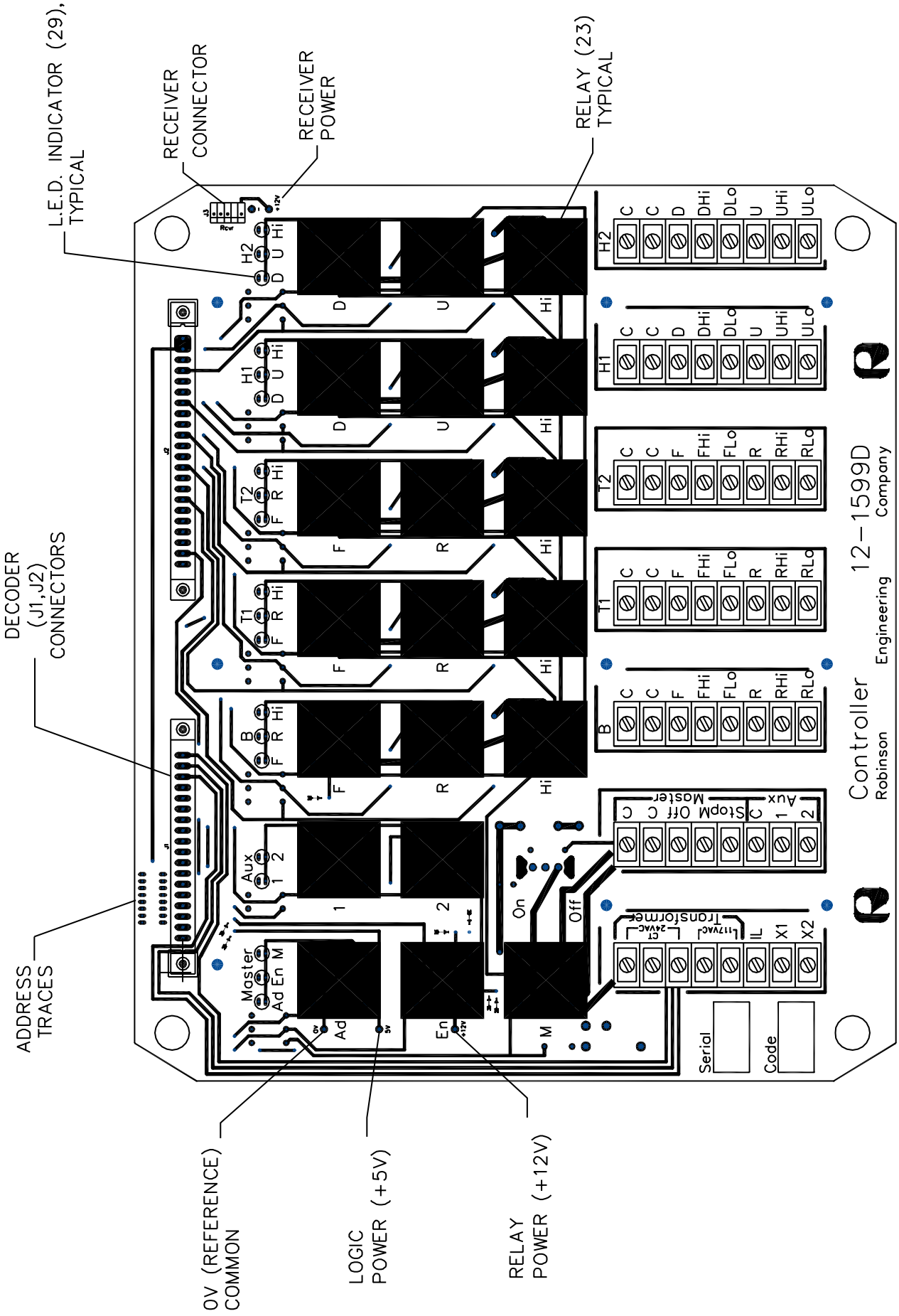

FIG. 5-2

5.2.3.5 Voltage Checks:

Test Points	Voltage	Test for
Terminals "X1", "X2"	117 VAC	<u>Input power</u>
Terminals "117 VAC" (Neon indicator lighted)	117 VAC	Power <u>switch</u> "ON", Fuse OK.
Terminals "24 VAC" (2) And "CT"	24 VAC between designated Terminals), 12 VAC between "CT" and each of the above terminals.	Transformer Output.

Do the above checks with and without the Decoder plugged in.

Without: If any of the above checks fail to provide the noted voltage reading, the component involved should be repaired or replaced. (See "CAUTION", top of Page 5-5).

With: If any of the above checks fail to provide the noted voltage readings, the Decoder should be replaced. (See "CAUTION", top of Page 5-5).

Controller Board 0V and +5V (left of "Ad" relay)	5 ± .2 VDC	Decoder 5 VDC logic power.
Controller Board 0V and 12V (left of "En" relay)	15 to 18 VDC No Load.* 9.5 to 11.0 VDC under max relay load.	Decoder 12VDC relay power.
Controller Board +, - below "Rcvr" connector (12VDC)	15 to 18 VDC	Decoder 12 VDC receiver power.

*Note: The type of meter used will vary the "No Load" readings considerably.

If any of the above checks fail to provide the noted voltage readings,
The Decoder should be replaced. (See "CAUTION", top of page 5-5).

5.2.3.6 Receiver – use the Transmitter qualitative test, paragraph 5.2.2.2 to check the Receiver. If receiving range appears to be reduced, check antenna for defects and proper connections.

NOTE: The cable connecting the Receiver to the Controller should not be ignored. A continuity test may be appropriate. (See “CAUTION”, top of Page 5-5).

5.2.3.7 Decoder – The only check for a suspected defective Decoder is substitution of a spare module.

5.2.3.8 Controller – Refer to Schematic, Controller, for assistance in circuit tracing.

CAUTION: When the Master (and Main Contactor) is energized, any energized motion relay will cause crane motion.

With Transmitter “OFF” , all relays (and LEDs) should be de-energized.

Main Circuit – This circuit is designed to operate in the following sequence:

1. Transmitter “Off”, all relays de-energized.
2. Transmitter “ON”, Address and Enable relays energized.
3. Address and Enable relays energize Master Relay (M) if all Transmitter motion controls are “OFF”. Address relay must be energized before any other function relay may be energized.
4. De-energizing the Address Relay by turning the Transmitter “OFF” de-energizes the Main Contactor, Enable and Master relays.

The Master Relay is controlled by relay contact circuits only. An examination of the Schematic will reveal that any motion relay energized will prevent the Master Relay from being energized – and so will a missing relay or a relay with a defective contact. Trouble in this circuit or in the isolated output circuits connected to the Crane Controls can be located and corrected by conventional electrical circuit tracing techniques.

Safety Circuit – This circuit is a comparison circuit between the Address relay and the Enable relay condition providing for a system shut down in the event of a mis-match of more than a fraction of a second duration. This arrangement provides protection from a welded contact or false operation of either of these safety components.

5.3 REPLACEABLE PARTS

When purchasing parts from the factory, please provide the Serial Number of your equipment (see nameplate on Transmitter or Receiving Equipment).

	<u>Quantity/ System</u>	<u>Recommended Spare Parts</u>	<u>Quantity/ Spare Parts Kit</u>
5.3.1 Transmitting Equipment:			
Transmitter, Model 200 H	1	1	
Antenna	1	1	
5.3.2 Receiving Equipment:			
Control Receiver	1	1	1
Receiver Cable	1		
Antenna Cable	1		
Antenna	1	1	
Decoder	1	1	1
Fuse, 8AG-2A (not instrument rating)	1	5	5
Transformer, 117/24V (CT)	1	1	1
Controller (Relay PCB Assembly w/Relays)	1		

INDEX

Adjustments; Frequency,	5. /page 5-1
Antenna: Receiving: Installation,	4.2.4/page 4-2
&	4.6.1/page 4-7
Remote,	4.2.4.1/page 4-2
Battery; Voltage,	5.2.2.1/page 5-2
Coding; Address,	1.2.3/page 1-2
Address,	3.1/page 3
Address,	3.3.4/page 3-6
Address,	2.2.3/page 5-2
Frequency; Adjustment,	5./page 5-1
Carrier,	3.1/page 3-1
Marked,	5.2.2.3/page 5-2
Scanning,	3.3.2/page 3-5

INDEX

Operating;	Abnormal,	2.4/page 2-2
	Multiple System,	3.1/page 3-1
	Multiple Systems,	5.2.2.3/page 5-2
	Normal,	2.3/page 2-1
	Transmitter,	2.2/page 2-1
	Transmitter,	5.2.2.3/page 5-2
Output;	Contact Rating,	3.3.5/page 3-6
	Contact Rating,	4.5.2/page 4-6
	Contacts,	4.4.2/page 4-5
	Indicating Light,	4.2.3/page 4-1
	Logic Expanding,	4.5.3/page 4-6
Power;	Incoming A.C.,	4.2.5/page 4-2

Crane Boss 200

TROUBLESHOOTING INDEX

0. GENERAL

BACK-UP: 5.2.1

FAILSAFE: 1.2.3(2.), 2.3.7, 2.4

MODULARITY: 1.2.1(6.), FIG. 3-1 & 3-2, FIG. 5-1H & 5-2

INTERCHANGEABILITY: 3.2 & 3.3, 5.2.2 & 5.2.3

POWER SUPPLY: 2.1, 3.3.3, FIG. 4-1, 5.2.3.5

CODE: 1.2.3(4. & 7.), 3.1, 3.3.4, 5.2.2.3, 5.2.3.3, FIG. 5-2

I. TRANSMITTING & RECEIVING

BATTERY: 1.2.4, 5.2.2.2

OPERATION: SECTION 2, 3.1

FREQUENCY(S): 1.2.3(7.), 2.4(3.), 3.1, 3.2, 3.3.2, 4.6.1(5.), 4.6.2(3.)

SIGNAL(S): 3.2, 3.3.2, 5.2.2.2, 5.2.3.1

UNIVERSAL: 2.3(3.), 3.2, 5.2.2.3

ALL-STOP: 2.3(7.), 2.4, 3.1, 5.2.3.8

RECEIVING: 3.3.2, 5.2.2.2, 5.2.3.1

FIELD ADJUSTMENT: 1.2.3(6.), 3.3.2, 4.6.3(2.), 5.2.3.6

ANTENNA: 3.3.1, 4.2.4, 4.6.1(3.), 5.2.3.6

II. (EN)CODING & DECODING

ADDRESS: 1.2.3(7.), 2.3(3.), 3.1, 3.2, 3.3.2, 3.3.4, 5.2.2.3, 5.2.3.3, 5.2.3.8

“DRY RUN”: 5.2.3.4

DECODING: 3.3.3, 5.2.3.7

III. SAFETY & SEQUENCE

OPERATION: 2.3(5.), 2.4

SIGNAL(S): 3.3.5, 5.2.3.8

MASTER: 2.3(5.), 2.4, 5.2.3.8

IV. INPUTS & OUTPUTS

SWITCHES: 2.3(5. & 7.), 5.2.3.4

RELAYS: 3.3.5, 4.4.2, 4.4.3, 4.5, 5.2.3.4 & FIG. 5-2

RELAY CIRCUITS: 1.2.3(5.), 1.2.4, 4.4, 4.5, 5.2.3.8

OUTPUT CIRCUITS: FIG. 4-1 & 4-2

OPTIONS

* Variances per Option:

4.2.4.1 “Antenna” (4-7), see Remote Antenna Kit.

4.6.1 “Antenna” (4-2), see Remote Antenna.

OPTIONS

Remote Antenna Kit:

Mounting of the Receiving enclosure should allow for the Antenna to be

1. Clear of large metal objects, being greater than one foot away from bridge girders, hoist mechanism, etc;
2. In view from the entire operating area, in all directions
3. And not in close proximity to crane electrification, like runway conductors, bridge cross conductors, festooning, conduit or wire way.

If any of these conditions cannot be met, a Remote Antenna Kit should be used.

The Kit includes 10 ft. of add-on cabling with Antenna mounting plate attached and base for the plate.